

2mm Double-Row Connector (Product Compliant to UL/CSA Standard)

DF11 Series

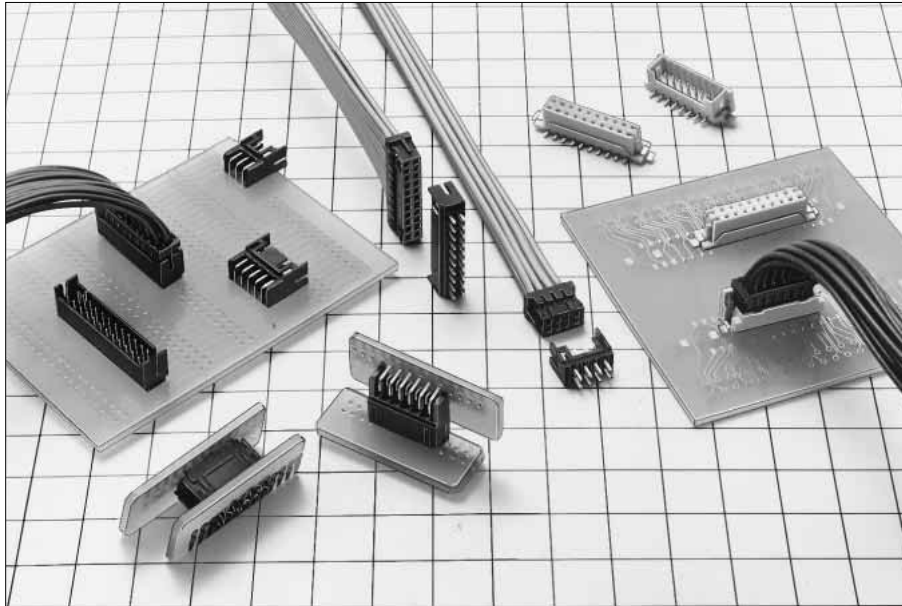

■ Features

1. Space-saving on Board Realized

Double rows of 2mm pitch contact has been condensed within the 5mm width.
The multiple number of signals can be secured in the same space as the conventional 2mm single-row contact.

2. Broad Variation

The insulation displacement and crimping methods are prepared for connection. Thus, board to cable, in-line, board to board connectors are provided in order to widen a board design variation.
In addition, "Gold" or "Tin" can be selected for the plating according application, while the SMT products line up.

3. Applicable Wire Covers Wide Range

According to the double rows of 2mm pitch compact design, the applicable wire can cover 22 to 30 AWG.

4. The ID Type Connector Achieves Connection Work.

Using the full automatic insulation displacement machine, the complicated multi-harness can be easily connected, reducing the man-hour and eliminating the manual work process.

■ Applications

Business equipments such as copy machine, printer and so on.

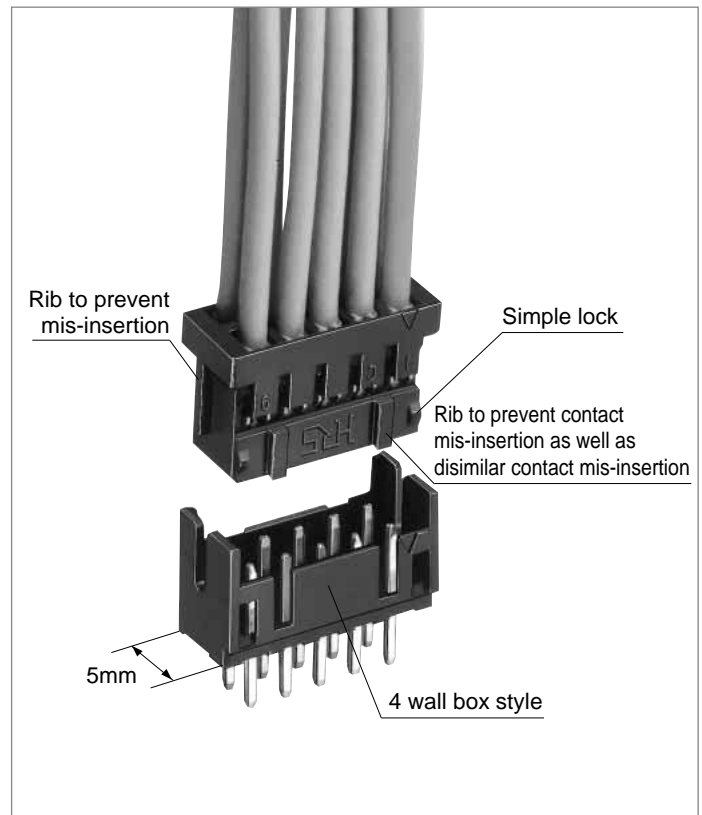

■ Features of DF11 Insulation Displacement Machine (Single Core Punching Full Automatic ID Machine AM700/DF11)

● 5 Major Features of ID Machine AM700/DF11

1. Perform the multi-harness.
2. The setup time has been widely reduced. (10 minutes maximum)
3. Space saving design.
(About half space compared with the conventional machine)
4. Minimize initial cost with low cost.
5. The harness data can be saved in the floppy disk and easily changed.

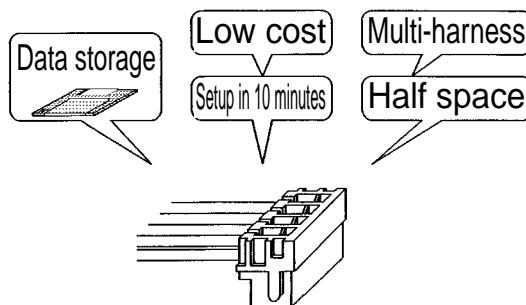

■ Points

Since the DF11 insulation displacement allows double rows ID with a single part, the harness service is completed with machine connection only.

■ Product Specifications

Rating	Current rating (Note 1)	Crimping	Wire size		Operating Temperature Range	Operating Humidity Range
			22 to 26 AWG : 2A	28 AWG : 1A		
26 AWG : 1A	250V AC	100V AC	Storage Humidity Range	40 to 70% (Note 4)		

UL-CSA Safety Standard Approved Specification			
Rating	Current rating	Wire size	
		22 AWG : 2A	24 to 28 AWG : 1A
		30 AWG : 0.5A	
Voltage rating		30V AC	

■ UL-CSA Safety Standard File No.

UL : E52653

CSA : LR95109

Item	Specification	Condition	
1. Insulation Resistance	1000MΩ min.	500V DC	
2. Withstanding voltage	No flashover or insulation breakdown.	650V AC/1 minute	
3. Contact Resistance	30mΩ max.	100mA	
4. Single Insertion/Extraction Force	0.3N (30gf) min., 4.4N(450gf) max.	Measured by the square steel-made pin of 0.5±0.002mm	
5. Vibration	No electrical discontinuity of 1μs or more	Frequency : 10 to 55 Hz, single amplitude of 0.75mm, 2 hours in each of the 3 directions.	
6. Humidity (Steady state)	Contact resistance : 30mΩ max. Insulation resistance : 500MΩ min.	96 hours at temperature of 40°C and humidity of 90% to 95%	
7. Temperature Cycle	Contact resistance : 30mΩ max. Insulation resistance : 1000MΩ min.	(-55°C : 30 minutes → 5 to 35°C : 5 to 15 minutes 85°C : 30 minutes → 5 to 35°C : 5 to 15 minutes) 5 cycles	
8. Durability (Mating/un-mating)	Contact resistance : 30mΩ max.	Tin plated : 30 cycles Gold plated : 50 cycles	
9. Resistance to Soldering heat	No deformation of components affecting performance.	Flow : 260°C for 10 seconds	Manual soldering : 300°C for 2 seconds
		Reflow : At the recommended temperature profile	Manual soldering : 300°C for 3 seconds

Note 1 : This is the maximum current rating while all pins are powered or used as all power lines. When isolating power lines into multiple circuits, current ratings may go above the stated current ratings. Please consult Hirose for specific details before doing this.
Current rating of header is 2A.

Note 2 : Includes the temperature rise of power lines.

Note 3 : The connector should be completely dry. (no condensation present)

Note 4 : The term "storage" refers to the long-term storage condition of unused products before PCB mounting. The operating temperature and humidity ranges are applied while in a non-energized state, while in transport or after PCB mounting.

Note 5 : Information contained in this catalog represents general requirements for this Series. Contact us for the drawings and specifications for a specific part number shown.

Material / Finish

Product Type	Part	Material	Finish	Remarks
Crimping Socket	Insulator	Polyamide	Black	UL94V-0
Crimping Contact for Socket	Contact	Phosphor copper	Tin plated or gold plated	————
ID Socket	Insulator	Polyamide	Black	UL94V-0
	Contact	Phosphor copper	Tin plated	————
Receptacle	Insulator	Polyamide	Black	UL94V-0
	Contact	Phosphor copper	Tin plated or gold plated	————
Pin Header	Insulator	Polyamide	Black	UL94V-0
	Contact	Brass	Tin plated or gold plated	————
SMT Header	Insulator	Polyamide	Beige	UL94V-0
	Contact	Brass	Tin plated or gold plated	————
	Metal fittings	Brass	Tin plated	————
In-line Plug	Insulator	Polyamide	Black	UL94V-0
In-line Plug Crimping Contact	Contact	Phosphor copper	Tin plated or gold plated	————
In-line Adaptor	Insulator	Polyamide	Black	UL94V-0
	Contact	Brass	Tin plated	————

Product Number Structure

Refer to the chart below when determining the product specifications from the product number. Please select from the product numbers listed in this catalog when placing orders.

● Connector

DF11 - * DS - 2C
 ① ② ③ ④ ⑤

① Series Name : DF11	⑤ Connection Form/Contact Style
② Number of Contacts : 4 to 32	C : Crimping socket
③ Connector Type	R26 : Insulation Displacement socket for AWG26
	DSA : Straight through hole
	DS : Right angle through hole
DP : Double Row pin header	V : Straight SMT
DEP : Double Row in-line plug	A : Adaptor
④ Contact Pitch : 2mm	

● Contact

DF11 - EP2428PCFA
 ① ② ③ ④

① Contact Type	Blank : For socket	③ Contact Type/Packaging Type	SCF : Socket contact, Embossed tape
	EP : For in-line plug		SC : Socket contact, Bag
② Applicable Wire Size	22 : 22 AWG	PCF : Plug contact, Embossed tape	④ Plating Type
	2428 : 24 to 28 AWG	PC : Plug contact, Bag	
	30 : 30 AWG		
			Blank : Tin plated
			A : Gold plated

■ ID Socket

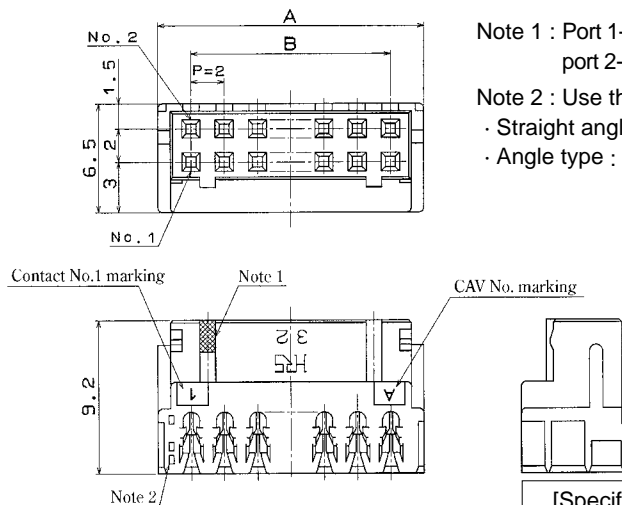
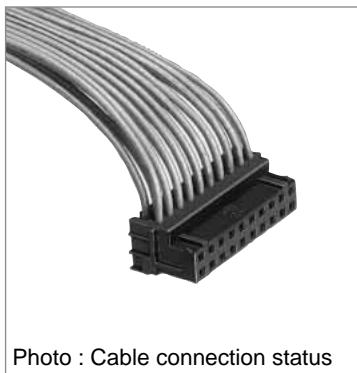

Note 1 : Port 1-piece indicates odd number row, and port 2- pcs. indicate even number row.

Note 2 : Use the dip type header as follows.
 · Straight angle type : DF11-***DP-2DSA(08)**
 · Angle type : DF11-***DP-2DS(24)**

[Specific No.] -** *, (** *)
 (05) : Tin plated, 100 pcs. per bag
 (25) : Tin plated, Tube packaging

Unit : mm

Part No.	HRS No.	No. of Contacts	A	B	Tube Packaging Quantity
DF11- 4DS-2R26(**)	543-0652-0 **	4	6.0	2.0	188
DF11- 6DS-2R26(**)	543-0653-3 **	6	8.0	4.0	140
DF11- 8DS-2R26(**)	543-0654-6 **	8	10.0	6.0	112
DF11-10DS-2R26(**)	543-0655-9 **	10	12.0	8.0	94
DF11-12DS-2R26(**)	543-0656-1 **	12	14.0	10.0	80
DF11-14DS-2R26(**)	543-0657-4 **	14	16.0	12.0	70
DF11-16DS-2R26(**)	543-0658-7 **	16	18.0	14.0	62
DF11-18DS-2R26(**)	543-0659-0 **	18	20.0	16.0	56
DF11-20DS-2R26(**)	543-0660-9 **	20	22.0	18.0	50
DF11-22DS-2R26(**)	543-0661-1 **	22	24.0	20.0	46
DF11-24DS-2R26(**)	543-0662-4 **	24	26.0	22.0	42
DF11-26DS-2R26(**)	543-0663-7 **	26	28.0	24.0	40
DF11-28DS-2R26(**)	543-0664-0 **	28	30.0	26.0	36
DF11-30DS-2R26(**)	543-0665-2 **	30	32.0	28.0	34
DF11-32DS-2R26(**)	543-0666-5 **	32	34.0	30.0	32

Note 1 : The specific No. (05) item is delivered per bag unit (100 pcs.). Please order products per bag unit.

Note 2 : To use the full automatic insulation displacement machine to punch the DF11 single contact, the (25) tube packaging specification should be applied.

Note 3 : Please order the tube packaging products by multiplying the packaging quantity (pcs.).

■ Applicable Cable

Part No.	Applicable Cable	Jacket Diameter
DF11- *DS-2R26	UL1061 26 AWG (7/0.16)	φ0.9 to 1.05mm

■ DF11-***DS-2R** Insulation Displacement Machine

Type	Part No.	Connection Type	Remarks
Punching full automatic ID machine DF11 single contact	AM700/DF11	<ul style="list-style-type: none"> ■Effective harness form <ol style="list-style-type: none"> 1. DF11-both ended, one ended 2. DF11-DF11, separation 3. DF11-DF3, separation ■Effective harness length 100 to 2,000mm ■Continuity Inspection Mechanism Equipped 	The connector is applicable to (25) tube packaging.
Desktop ID Machine	SA700/DF11 903-0013-5	<ul style="list-style-type: none"> ■Used for DF11 only, No restricted condition 	Desktop machine for small lot

■Crimping Socket

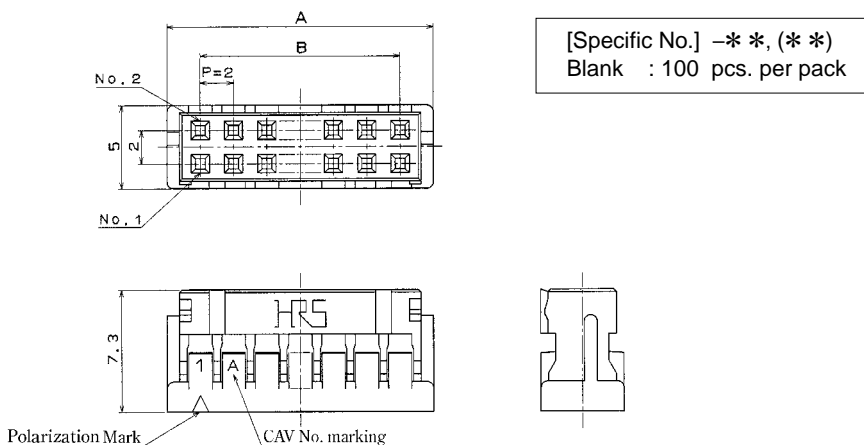
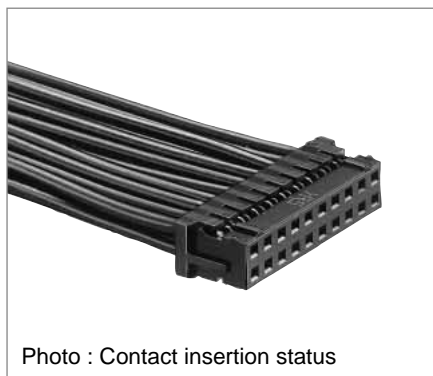

Part No.	HRS No.	No. of Contacts	A	B
DF11- 4DS-2C(**)	543-0568-6 **	4	6.0	2.0
DF11- 6DS-2C(**)	543-0502-8 **	6	8.0	4.0
DF11- 8DS-2C(**)	543-0503-0 **	8	10.0	6.0
DF11-10DS-2C(**)	543-0504-3 **	10	12.0	8.0
DF11-12DS-2C(**)	543-0505-6 **	12	14.0	10.0
DF11-14DS-2C(**)	543-0506-9 **	14	16.0	12.0
DF11-16DS-2C(**)	543-0507-1 **	16	18.0	14.0
DF11-18DS-2C(**)	543-0508-4 **	18	20.0	16.0

Part No.	HRS No.	No. of Contacts	A	B
DF11-20DS-2C(**)	543-0509-7 **	20	22.0	18.0
DF11-22DS-2C(**)	543-0510-6 **	22	24.0	20.0
DF11-24DS-2C(**)	543-0511-9 **	24	26.0	22.0
DF11-26DS-2C(**)	543-0512-1 **	26	28.0	24.0
DF11-28DS-2C(**)	543-0513-4 **	28	30.0	26.0
DF11-30DS-2C(**)	543-0514-7 **	30	32.0	28.0
DF11-32DS-2C(**)	543-0515-0 **	32	34.0	30.0

Note : Delivered per bag unit (100 pcs.). Please order products bag pack unit.

■Receptacle (DIP)

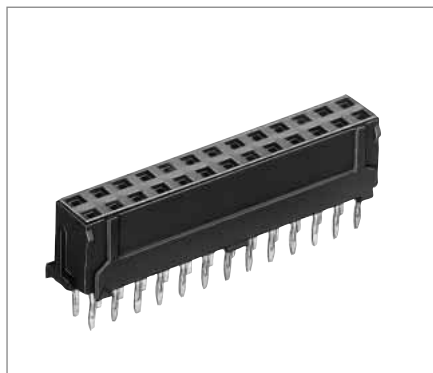

- Board Through-hole Diameter : $\phi 0.8^{+0.1}$
- Kink Prefixed Effective Diameter : $\phi 0.8^{+0.05}$

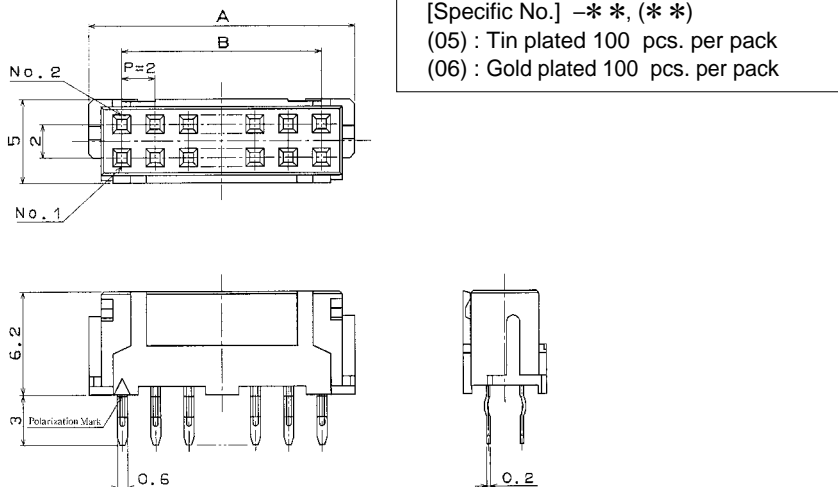

Part No.	HRS No.	No. of Contacts	A	B
DF11- 6DS-2DSA(**)	543-0553-9 **	6	8.0	4.0
DF11- 8DS-2DSA(**)	543-0554-1 **	8	10.0	6.0
DF11-10DS-2DSA(**)	543-0555-4 **	10	12.0	8.0
DF11-12DS-2DSA(**)	543-0556-7 **	12	14.0	10.0
DF11-14DS-2DSA(**)	543-0557-0 **	14	16.0	12.0
DF11-16DS-2DSA(**)	543-0558-2 **	16	18.0	14.0
DF11-18DS-2DSA(**)	543-0559-5 **	18	20.0	16.0

Part No.	HRS No.	No. of Contacts	A	B
DF11-20DS-2DSA(**)	543-0560-4 **	20	22.0	18.0
DF11-22DS-2DSA(**)	543-0561-7 **	22	24.0	20.0
DF11-24DS-2DSA(**)	543-0562-0 **	24	26.0	22.0
DF11-26DS-2DSA(**)	543-0563-2 **	26	28.0	24.0
DF11-28DS-2DSA(**)	543-0564-5 **	28	30.0	26.0
DF11-30DS-2DSA(**)	543-0565-8 **	30	32.0	28.0
DF11-32DS-2DSA(**)	543-0566-0 **	32	34.0	30.0

Note : Delivered per bag unit (100 pcs.). Please order products per bag unit.

■ Receptacle (SMT)

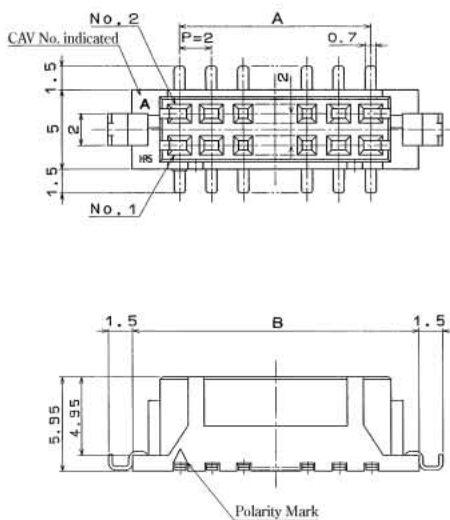
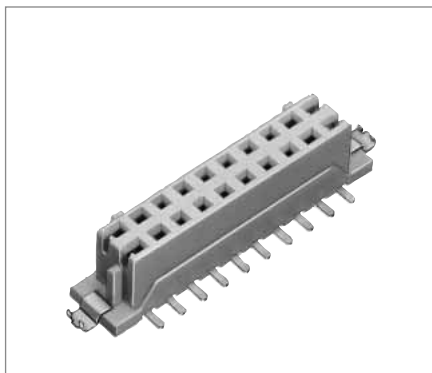

[Specific No.] - * *, (* *)
 (22) : Tin plated embossed tape packaging
 (with vacuum pick-up cap)
 (52) : Gold plated embossed tape packaging
 (with vacuum pick-up cap)

Unit : mm

Part No.	HRS No.	No. of Contacts	A	B	C
DF11CZ- 4DS-2V(**)	543-2063-0 **	4	2.0	8.5	8.7
DF11CZ- 6DS-2V(**)	543-2064-3 **	6	4.0	10.5	10.7
DF11CZ- 8DS-2V(**)	543-2065-6 **	8	6.0	12.5	12.7
DF11CZ-10DS-2V(**)	543-2066-9 **	10	8.0	14.5	14.7
DF11CZ-18DS-2V(**)	543-2070-6 **	18	16.0	22.5	22.7
DF11CZ-20DS-2V(**)	543-2071-9 **	20	18.0	24.5	24.7
DF11CZ-22DS-2V(**)	543-2072-1 **	22	20.0	26.5	26.7
DF11CZ-26DS-2V(**)	543-2074-7 **	26	24.0	30.5	30.7
DF11CZ-30DS-2V(**)	543-2076-2 **	30	28.0	34.5	34.7
DF11CZ-40DS-2V(**)	543-0584-2 **	40	38.0	44.5	44.7

Note 1 : Tape and reel packaging(500 pieces/reel). Order by number of reels.

Note 2 : The 40 contacts connector is merchandized only in combination with the SMT product.

Note 3 : Embossed packaging products have the reel wrapped in polyethylene and include a desiccant.

◆ PCB mounting pattern

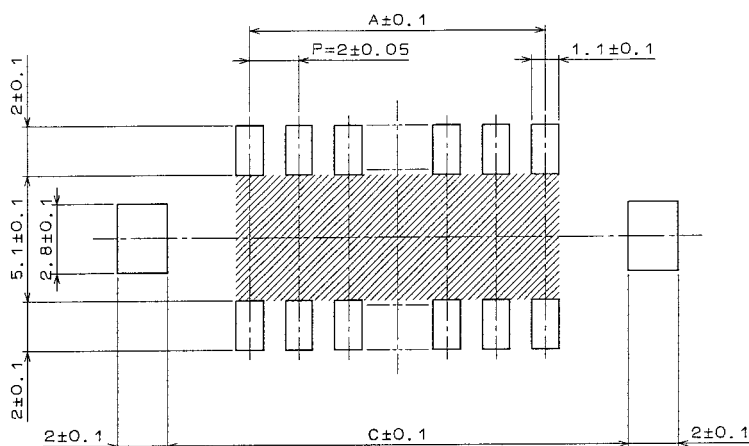

Note : If the pattern is included in the shaded area and not treated with resist, it could touch the connector contact .

■ Straight Pin Header

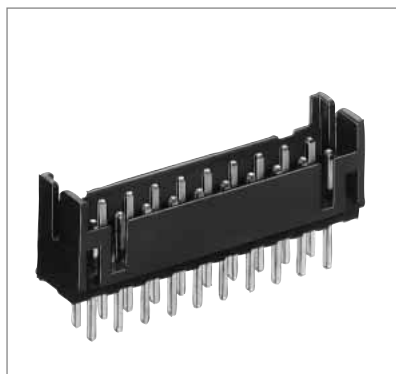

● Board Through-hole Diameter : $\phi 0.8^{+0.1}_0$

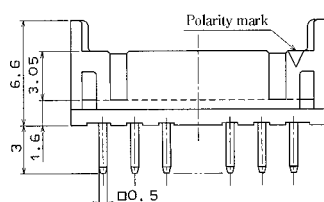
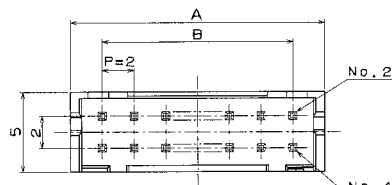

[Specific No.] - * *, (* *)
 (01) : Gold plated
 (08) : Tin plated
 (24) : Tin plated tube package product

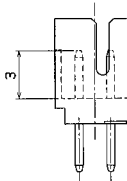

Unit : mm

Part No.	HRS No.	No. of Contacts	A	B	Tube Package Quantity
DF11- 4DP-2DSA(**)	543-0517-5 **	4	6.0	2.0	81pcs.
DF11- 6DP-2DSA(**)	543-0518-8 **	6	8.0	4.0	61
DF11- 8DP-2DSA(**)	543-0519-0 **	8	10.0	6.0	49
DF11-10DP-2DSA(**)	543-0520-0 **	10	12.0	8.0	40
DF11-12DP-2DSA(**)	543-0521-2 **	12	14.0	10.0	34
DF11-14DP-2DSA(**)	543-0522-5 **	14	16.0	12.0	30
DF11-16DP-2DSA(**)	543-0523-8 **	16	18.0	14.0	27
DF11-18DP-2DSA(**)	543-0524-0 **	18	20.0	16.0	24

Part No.	HRS No.	No. of Contacts	A	B	Tube Package Quantity
DF11-20DP-2DSA(**)	543-0525-3 **	20	22.0	18.0	22pcs.
DF11-22DP-2DSA(**)	543-0526-6 **	22	24.0	20.0	20
DF11-24DP-2DSA(**)	543-0527-9 **	24	26.0	22.0	18
DF11-26DP-2DSA(**)	543-0528-1 **	26	28.0	24.0	17
DF11-28DP-2DSA(**)	543-0529-4 **	28	30.0	26.0	16
DF11-30DP-2DSA(**)	543-0530-3 **	30	32.0	28.0	15
DF11-32DP-2DSA(**)	543-0531-6 **	32	34.0	30.0	14

Note 1 : Specific No. (01) and (08) items are delivered per bag unit (100 pcs.). Please order products per bagunit.

Note 2 : Please order the tube packaging products, by multiplying a tube quantity(pcs.).

■ Right Angle Pin Header



● Board Through-hole Diameter : $\phi 0.8^{+0.1}_0$

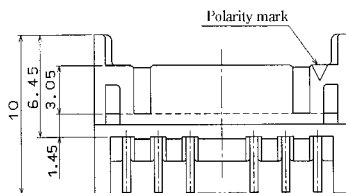
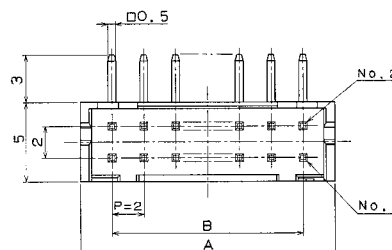

[Specific No.] - * *, (* *)
 (24) : Tin plated tube packaging product
 (52) : Gold plated tube packaging product

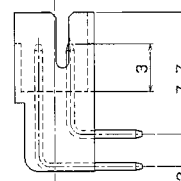

Unit : mm

Part No.	HRS No.	No. of Contacts	A	B	Tube Package Quantity
DF11- 4DP-2DS(**)	543-0533-1 **	4	6.0	2.0	81pcs.
DF11- 6DP-2DS(**)	543-0534-4 **	6	8.0	4.0	61
DF11- 8DP-2DS(**)	543-0535-7 **	8	10.0	6.0	48
DF11-10DP-2DS(**)	543-0536-0 **	10	12.0	8.0	40
DF11-12DP-2DS(**)	543-0537-2 **	12	14.0	10.0	34
DF11-14DP-2DS(**)	543-0538-5 **	14	16.0	12.0	30
DF11-16DP-2DS(**)	543-0539-8 **	16	18.0	14.0	27
DF11-18DP-2DS(**)	543-0540-7 **	18	20.0	16.0	24

Part No.	HRS No.	No. of Contacts	A	B	Tube Package Quantity
DF11-20DP-2DS(**)	543-0541-0 **	20	22.0	18.0	22pcs.
DF11-22DP-2DS(**)	543-0542-2 **	22	24.0	20.0	20
DF11-24DP-2DS(**)	543-0543-5 **	24	26.0	22.0	18
DF11-26DP-2DS(**)	543-0544-8 **	26	28.0	24.0	17
DF11-28DP-2DS(**)	543-0545-0 **	28	30.0	26.0	16
DF11-30DP-2DS(**)	543-0546-3 **	30	32.0	28.0	15
DF11-32DP-2DS(**)	543-0547-6 **	32	34.0	30.0	14

Note 1 : Please order the tube packaging product by multiplying a tube quantity(pcs.).

■ Straight Pin Header (SMT)

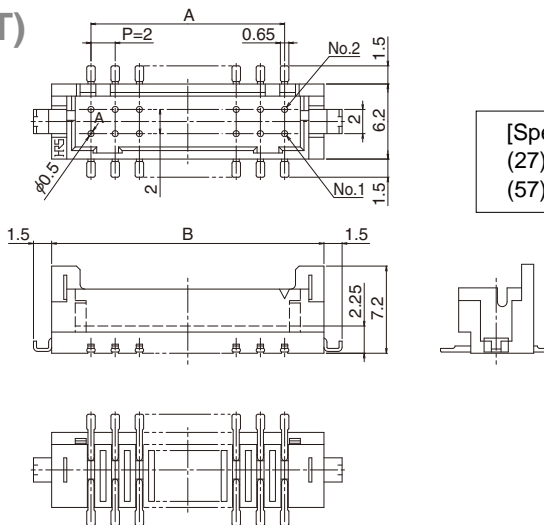

[Specific No.] - * *, (* *)
 (27) : Tin plated embossed tape packaging
 (57) : Gold plated embossed tape packaging

Unit : mm

Tin plated		Gold plated		No. of Contacts	A	B	C
Part No.	HRS No.	Part No.	HRS No.				
DF11CZ- 4DP-2V(27)	543-2047-4 27	DF11C- 4DP-2V(57)	543-0682-1 57	4	2.0	8.5	8.7
DF11CZ- 6DP-2V(27)	543-2048-7 27	DF11C- 6DP-2V(57)	543-0683-4 57	6	4.0	10.5	10.7
DF11CZ- 8DP-2V(27)	543-2049-0 27	DF11C- 8DP-2V(57)	543-0684-7 57	8	6.0	12.5	12.7
DF11CZ-10DP-2V(27)	543-2050-9 27	DF11C-10DP-2V(57)	543-0685-0 57	10	8.0	14.5	14.7
DF11CZ-12DP-2V(27)	543-2051-1 27	DF11C-12DP-2V(57)	543-0686-2 57	12	10.0	16.5	16.7
DF11CZ-14DP-2V(27)	543-2052-4 27	DF11C-14DP-2V(57)	543-0687-5 57	14	12.0	18.5	18.7
DF11CZ-16DP-2V(27)	543-2053-7 27	DF11C-16DP-2V(57)	543-0688-8 57	16	14.0	20.5	20.7
DF11CZ-18DP-2V(27)	543-2054-0 27	DF11C-18DP-2V(57)	543-0689-0 57	18	16.0	22.5	22.7
DF11CZ-20DP-2V(27)	543-2055-2 27	DF11C-20DP-2V(57)	543-0690-0 57	20	18.0	24.5	24.7
DF11CZ-22DP-2V(27)	543-2056-5 27	DF11C-22DP-2V(57)	543-0691-2 57	22	20.0	26.5	26.7
DF11CZ-24DP-2V(27)	543-2057-8 27	DF11C-24DP-2V(57)	543-0692-5 57	24	22.0	28.5	28.7
DF11CZ-26DP-2V(27)	543-2058-0 27	DF11C-26DP-2V(57)	543-0693-8 57	26	24.0	30.5	30.7
DF11CZ-28DP-2V(27)	543-2059-3 27	DF11C-28DP-2V(57)	543-0694-0 57	28	26.0	32.5	32.7
DF11CZ-30DP-2V(27)	543-2060-2 27	DF11C-30DP-2V(57)	543-0695-3 57	30	28.0	34.5	34.7
DF11CZ-32DP-2V(27)	543-2061-5 27	DF11C-32DP-2V(57)	543-0696-6 57	32	30.0	36.5	36.7
DF11CZ-40DP-2V(27)	543-2062-8 27	DF11C-40DP-2V(57)	543-0697-9 57	40	38.0	44.5	44.7

Note 2

Note 1 : Tape and reel packaging(500 pieces/reel). Order by number of reels.

Note 2 : The 40 contacts connector is merchandized in combination with the SMT product.

Note 3 : Embossed packaging products have the reel wrapped in polyethylene and include a desiccant.

◆ PCB mounting pattern

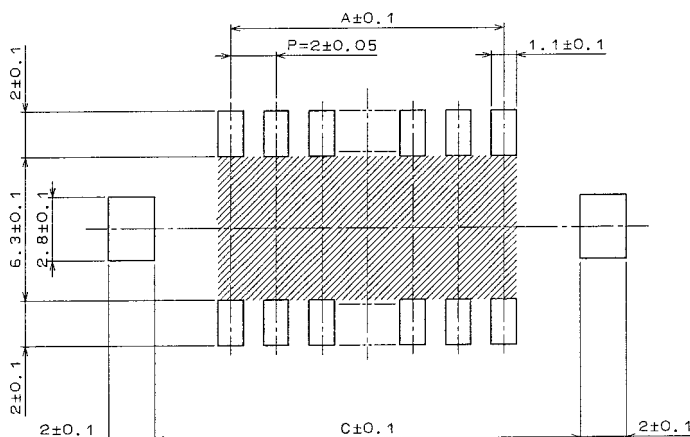

Note : If the pattern is included in the shaded area and not treated with resist, it could contact to the connector contact .

■ In-line Plug

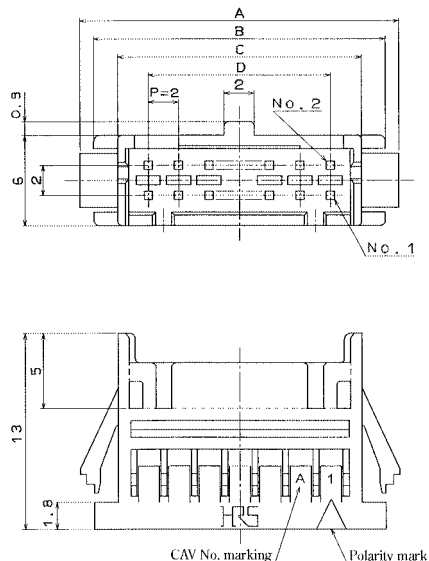
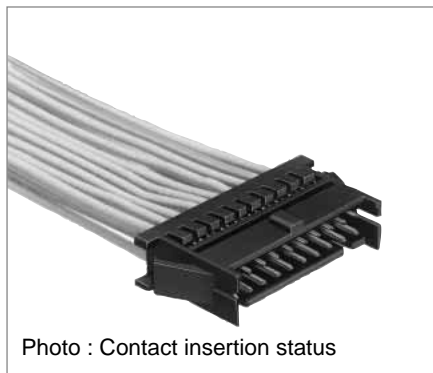

◆ In-line Plug Panel Cutouts

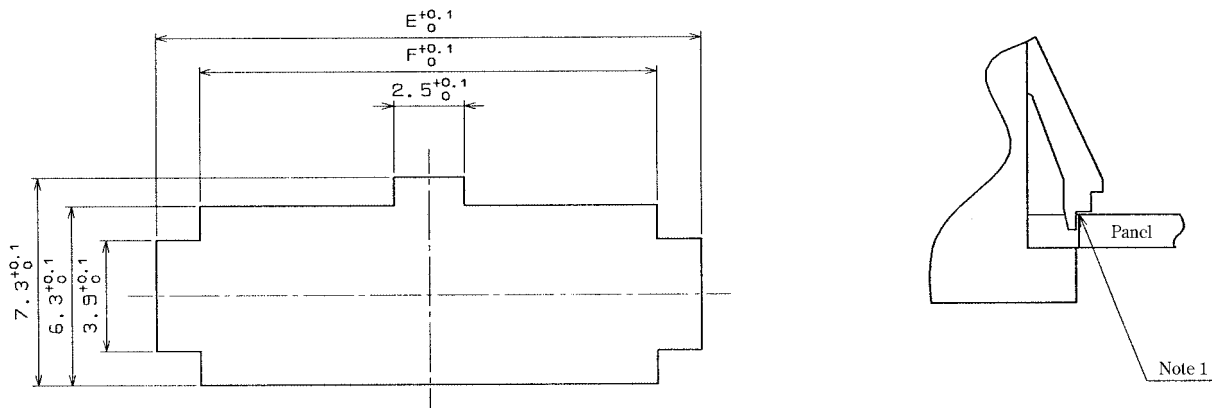

Note 1 : Please use the non-radius side for the panel hooking area.

Note 2 : Applicable panel thicknessing is 1.6 to 1.0mm (A slight deviation will occur for the thickness except for 1.6 and 1.2mm.)

Unit : mm

Part No.	HRS No.	No. of Contacts	A	B	C	D	E	F
DF11- 4DEP-2C	543-0619-5	4	11.0	9.2	6.0	2.0	9.4	6.3
DF11- 6DEP-2C	543-0620-4	6	13.0	11.2	8.0	4.0	11.4	8.3
DF11- 8DEP-2C	543-0621-7	8	15.0	13.2	10.0	6.0	13.4	10.3
DF11-10DEP-2C	543-0622-0	10	17.0	15.2	12.0	8.0	15.4	12.3
DF11-12DEP-2C	543-0623-2	12	19.0	17.2	14.0	10.0	17.4	14.3
DF11-14DEP-2C	543-0624-5	14	21.0	19.2	16.0	12.0	19.4	16.3
DF11-16DEP-2C	543-0625-8	16	23.0	21.2	18.0	14.0	21.4	18.3
DF11-18DEP-2C	543-0626-0	18	25.0	23.2	20.0	16.0	23.4	20.3
DF11-20DEP-2C	543-0627-3	20	27.0	25.2	22.0	18.0	25.4	22.3
DF11-22DEP-2C	543-0628-6	22	29.0	27.2	24.0	20.0	27.4	24.3
DF11-24DEP-2C	543-0629-9	24	31.0	29.2	26.0	22.0	29.4	26.3
DF11-26DEP-2C	543-0630-8	26	33.0	31.2	28.0	24.0	31.4	28.3
DF11-28DEP-2C	543-0631-0	28	35.0	33.2	30.0	26.0	33.4	30.3
DF11-30DEP-2C	543-0632-3	30	37.0	35.2	32.0	28.0	35.4	32.3
DF11-32DEP-2C	543-0633-6	32	39.0	37.2	34.0	30.0	37.4	34.3

Note 1 : Delivered per bag unit (100 pcs.). Please order products per bag unit.

In-line Adaptor

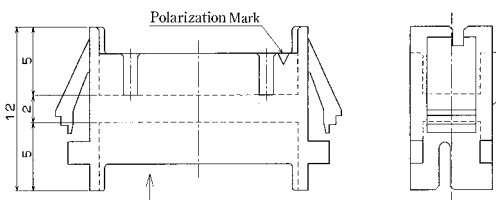
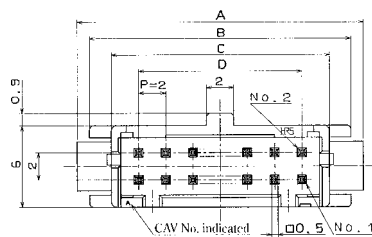

Note: On this side, higher insertion or extraction force is set.

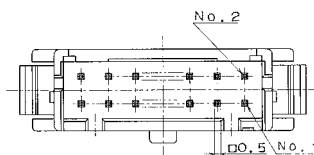

In-line Adaptor Panel Cutouts

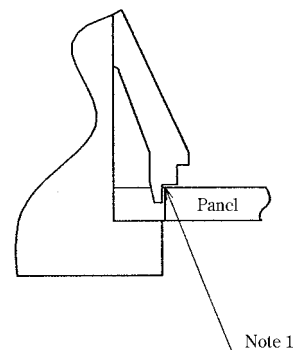
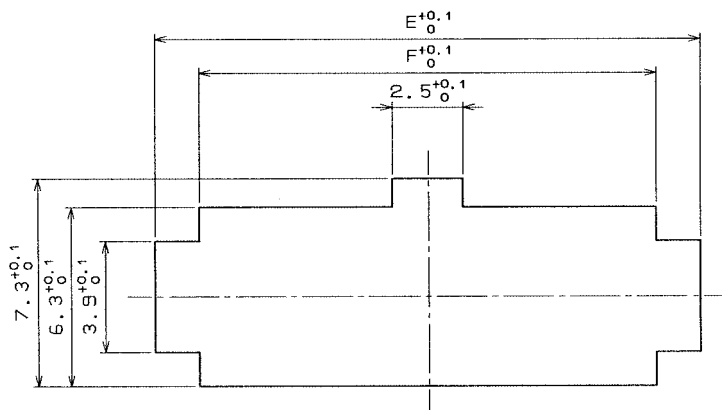

Note 1 : Please use the non-radius surface in the panel hooking area.

Note 2 : Applicable panel thickness is 1.6 to 1.0mm (A slight backlash will occur in the thickness other than 1.6 and 1.2mm.)

Unit : mm

Part No.	HRS No.	No. of Contacts	A	B	C	D	E	F
DF11- 4DEP-2A	543-0698-1	4	11.0	9.2	6.0	2.0	9.4	6.3
DF11- 6DEP-2A	543-0699-4	6	13.0	11.2	8.0	4.0	11.4	8.3
DF11- 8DEP-2A	543-0700-1	8	15.0	13.2	10.0	6.0	13.4	10.3
DF11-10DEP-2A	543-0701-4	10	17.0	15.2	12.0	8.0	15.4	12.3
DF11-12DEP-2A	543-0702-7	12	19.0	17.2	14.0	10.0	17.4	14.3
DF11-14DEP-2A	543-0703-0	14	21.0	19.2	16.0	12.0	19.4	16.3
DF11-16DEP-2A	543-0704-2	16	23.0	21.2	18.0	14.0	21.4	18.3
DF11-18DEP-2A	543-0705-5	18	25.0	23.2	20.0	16.0	23.4	20.3
DF11-20DEP-2A	543-0706-8	20	27.0	25.2	22.0	18.0	25.4	22.3
DF11-22DEP-2A	543-0707-0	22	29.0	27.2	24.0	20.0	27.4	24.3
DF11-24DEP-2A	543-0708-3	24	31.0	29.2	26.0	22.0	29.4	26.3
DF11-26DEP-2A	543-0709-6	26	33.0	31.2	28.0	24.0	31.4	28.3
DF11-28DEP-2A	543-0710-5	28	35.0	33.2	30.0	26.0	33.4	30.3
DF11-30DEP-2A	543-0711-8	30	37.0	35.2	32.0	28.0	35.4	32.3
DF11-32DEP-2A	543-0712-0	32	39.0	37.2	34.0	30.0	37.4	34.3

Note 1 : Delivered per bag unit (100 pcs.). Please order products per bag unit.

■ Crimping Contact for Socket

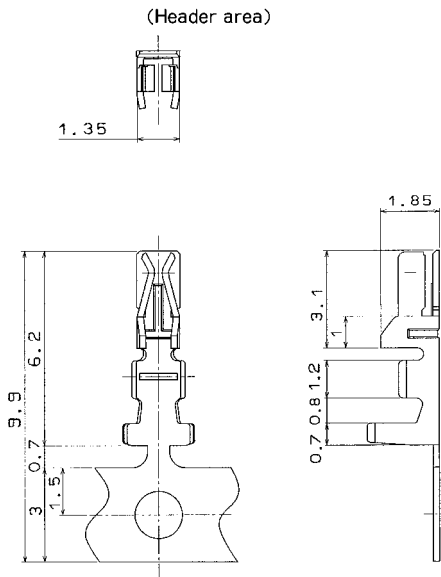

◆ Reel contact (10,000 pcs/reel) *Applicable tool : Applicator

Part No.	HRS No.	Finish	Applicable wire (Tin plated annealed copper wire) (Note 2)				
			UL	Wire size	Stranded wire conductor	Calculated cross-section	Jacket outer diameter
DF11-22SCF	543-0601-0	Tin plated	1061	22 AWG	17 / 0.16mm	0.342mm ²	1.2 to 1.45mm
DF11-22SCFA (04)	543-0603-5 04	Gold plated	1061	22 AWG	17 / 0.16mm	0.342mm ²	1.2 to 1.45mm
DF11-2428SCF	543-0500-0	Tin plated	1061, 1007	24 AWG	11 / 0.16mm	0.221mm ²	0.9 to 1.45mm
				26 AWG	7 / 0.16mm	0.141mm ²	
				28 AWG	7 / 0.127mm	0.089mm ²	
DF11A-2428SCF (Note 1)	543-0634-9	Tin plated	1061, 1007	24 AWG	11 / 0.16mm	0.221mm ²	0.9 to 1.45mm
				26 AWG	7 / 0.16mm	0.141mm ²	
				28 AWG	7 / 0.127mm	0.089mm ²	
DF11-2428SCFA (04)	543-0550-0 04	Gold plated	1061, 1007	24 AWG	11 / 0.16mm	0.221mm ²	0.9 to 1.45mm
				26 AWG	7 / 0.16mm	0.141mm ²	
				28 AWG	7 / 0.127mm	0.089mm ²	
DF11-30SCF	543-0605-0	Tin plated	1061, 1007	30 AWG	7 / 0.1mm	0.055mm ²	0.75 to 1.2mm
DF11-30SCFA (04)	543-0607-6 04	Gold plated	1061, 1007	30 AWG	7 / 0.1mm	0.055mm ²	0.75 to 1.2mm

Note 1 : DF11A-2428SCF is of tin plated low insertion/extraction type.

Note 2 : When using other than the recommended wire, contact your nearest Hirose sales representative.
Note 3 : The strip length is a reference value. Please make adjustments so finished crimps will meet the specified values. Refer to the crimping quality standards (ETAD-H0773-00) for details.

Note 4 : As this product is sold 10,000 pcs/reel, please place orders by the multiple of the number of reels.

◆ Strip Length
1.7 to 2.3mm

◆ Loose piece (1pack, 100) *Applicable tool : Hand crimping tool

Part No.	HRS No.	Finish	Applicable wire (Tin plated annealed copper wire) (Note 2)					
			UL	Wire size	Stranded wire conductor	Calculated cross-section	Jacket outer diameter	
DF11-22SC	543-0602-2	Tin plated	1061	22 AWG	17 / 0.16mm	0.342mm ²	1.3mm	
DF11-22SCA	543-0604-8	Gold plated	1061	22 AWG	17 / 0.16mm	0.342mm ²	1.3mm	
DF11-2428SC	543-0501-5	Tin plated	1061	24 AWG	11 / 0.16mm	0.221mm ²	1.1mm	
				26 AWG	7 / 0.16mm	0.141mm ²	1.0mm	
				28 AWG	7 / 0.127mm	0.089mm ²	0.9mm	
				1007	24 AWG	11 / 0.16mm	0.221mm ²	1.45mm
					26 AWG	7 / 0.16mm	0.141mm ²	1.3mm
					28 AWG	7 / 0.127mm	0.089mm ²	1.2mm
DF11A-2428SC (Note 1)	543-0635-1	Tin plated	1061	24 AWG	11 / 0.16mm	0.221mm ²	1.1mm	
				26 AWG	7 / 0.16mm	0.141mm ²	1.0mm	
				28 AWG	7 / 0.127mm	0.089mm ²	0.9mm	
				1007	24 AWG	11 / 0.16mm	0.221mm ²	1.45mm
					26 AWG	7 / 0.16mm	0.141mm ²	1.3mm
					28 AWG	7 / 0.127mm	0.089mm ²	1.2mm
DF11-2428SCA	543-0551-3	Gold plated	1061	24 AWG	11 / 0.16mm	0.221mm ²	1.1mm	
				26 AWG	7 / 0.16mm	0.141mm ²	1.0mm	
				28 AWG	7 / 0.127mm	0.089mm ²	0.9mm	
				1007	24 AWG	11 / 0.16mm	0.221mm ²	1.45mm
					26 AWG	7 / 0.16mm	0.141mm ²	1.3mm
					28 AWG	7 / 0.127mm	0.089mm ²	1.2mm
DF11-30SC	543-0606-3	Tin plated	1061	30 AWG	7 / 0.1mm	0.055mm ²	0.8mm	
DF11-30SCA	543-0608-9	Gold plated	1061	30 AWG	7 / 0.1mm	0.055mm ²	0.8mm	

Note 1 : DF11A-2428SC is of tin plated low insertion/extraction type.

Note 2 : When crimping using a hand crimping tool only the above wires are applicable.

Note 3 : The strip length is a reference value. Please make adjustments so finished crimps will meet the specified values. Refer to the crimping quality standards (ETAD-H0773-00) for details.

Note 4 : As this product is sold 100 pcs/pack, please place orders by the multiple of the number of packs.

■ Crimping Contact for In-line Plug

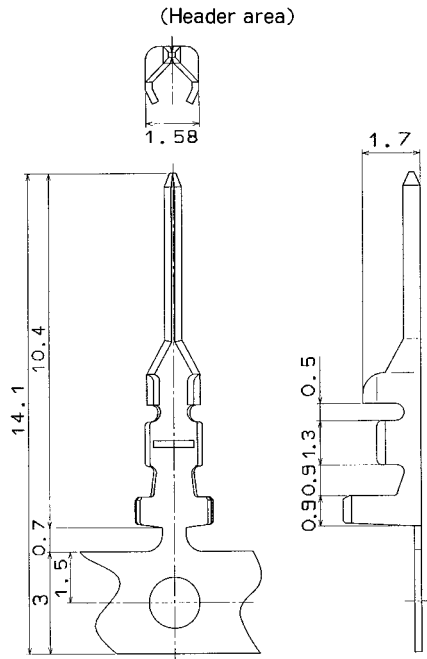

◆ Reel contact (10,000 pcs/reel) *Applicable tool : Applicator

Part No.	HRS No.	Finish	Applicable wire (Tin plated annealed copper wire) (Note 1)				
			UL	Wire size	Stranded wire conductor	Calculated cross-section	Jacket outer diameter
DF11-EP2428PCF	543-0615-4	Tin plated	1061, 1007	24 AWG	11 / 0.16mm	0.221mm ²	0.9 to 1.45mm
DF11-EP2428PCFA	543-0617-0	Gold plated	1061, 1007	26 AWG	7 / 0.16mm	0.141mm ²	
				28 AWG	7 / 0.127mm	0.089mm ²	
				24 AWG	11 / 0.16mm	0.221mm ²	
DF11-EP2428PCFA	543-0617-0	Gold plated	1061, 1007	26 AWG	7 / 0.16mm	0.141mm ²	0.9 to 1.45mm
				28 AWG	7 / 0.127mm	0.089mm ²	
				24 AWG	11 / 0.16mm	0.221mm ²	

Note 1 : When using other than the recommended wire, contact your nearest Hirose sales representative.

Note 2 : The strip length is a reference value. Please make adjustments so finished crimps will meet the specified values. Refer to the crimping quality standards (ETAD-H0935-00) for details.

Note 3 : As this product is sold 10,000 pcs/reel, please place orders by the multiple of the number of reels.

◆ Strip Length
1.9 to 2.3mm

◆ Loose piece (1pack, 100) *Applicable tool : Hand crimping tool

Part No.	HRS No.	Finish	Applicable wire (Tin plated annealed copper wire) (Note 1)				
			UL	Wire size	Stranded wire conductor	Calculated cross-section	Jacket outer diameter
DF11-EP2428PC	543-0616-7	Tin plated	1007	24 AWG	11 / 0.16mm	0.221mm ²	1.45mm
DF11-EP2428PCA	543-0618-2	Gold plated	1007	26 AWG	7 / 0.16mm	0.141mm ²	1.3mm
				28 AWG	7 / 0.127mm	0.089mm ²	1.2mm
				24 AWG	11 / 0.16mm	0.221mm ²	1.45mm
DF11-EP2428PCA	543-0618-2	Gold plated	1007	26 AWG	7 / 0.16mm	0.141mm ²	1.3mm
				28 AWG	7 / 0.127mm	0.089mm ²	1.2mm
				24 AWG	11 / 0.16mm	0.221mm ²	1.45mm

Note 1 : When crimping using a hand crimping tool only the above wires are applicable.

Note 2 : The strip length is a reference value. Please make adjustments so finished crimps will meet the specified values. Refer to the crimping quality standards (ETAD-H0935-00) for details.

Note 3 : As this product is sold 100 pcs/pack, please place orders by the multiple of the number of packs.

◆ Applicable Crimping Tool

Type	Part No.	HRS No.	Applicable contact
Applicator	AP105-DF11-22S	901-4529-7	DF11-22SCF DF11-22SCFA(04) DF11-2428SCF DF11A-2428SCF
	AP105-DF11-2428S	901-4511-1	DF11-2428SCF DF11-2428SCFA(04) DF11-30SCF
	AP105-DF11-30S	901-4532-1	DF11-30SCF(04)
	AP105-DF11-EP2428P	901-4528-4	DF11-EP2428PCF DF11-EP2428PCFA
	Press	CM-105C	901-0001-0
Hand crimping tool	DF11-TA22HC	550-0228-6	DF11-22SC DF11-22SCA DF11-2428SC DF11A-2428SC
	DF11-TA2428HC	550-0197-4	DF11-2428SCA DF11-30SC DF11-30SCA
	DF11-TA30HC	550-0230-8	DF11-30SC DF11-30SCA
	DF11EP-TA2428HC	550-0227-3	DF11-EP2428PC DF11-EP2428PCA
	Contact extraction tool	DF-C-PO(B)	550-0179-2

Note 1 : Please do the crimping operations according to the "Crimping quality standard (ETAD-H0773-00, ETAD-H0935-00)" and "Crimping condition table".

Note 2 : If any trouble has occurred due to tools other than the designated tool, Hirose bears no responsibility for any trouble.

◆ Crimping

■ Items required prior to start crimping

The work-related documents shown below are required before starting the harness connections.

(The ● mark shows the document required.)

When the documents shown below are not available, ask our sales personnel to provide them.

Document Title	Description	Automatic Crimping Machine	Hand Crimping Tool	Remarks
(1) Main unit of crimping machine instruction manual	Explanation of main press machine unit	●	—	When purchasing main press machine unit, it is bundled.
(2) Applicator Spare Parts Identification	Explanation for Applicator installation	●	—	When purchasing Applicator, it is bundled.
(3) Crimp Conditions	Standard values of : Crimp height ; Tensile strength	●	—	
(4) Crimp Quality Standards	Various standards for crimping conditions	●	—	
(5) Operating Instructions for Hand Tool	Inspection items of : Crimp height ; Tensile strength ; and others	—	●	When purchasing Hand Tool, it is bundled.
(6) Harness Procedure Manual ETAD-H0965-00	Harness procedure	●	●	Ask our sales personal to provide them.

■ Tools

When crimping work is applied to our contacts, the tool designated by Hirose should be used.

Crimping work by using tools other than as designated must not be done because it may result in contact failure, disconnection of cable, etc.

*The operating instructions manual is available for the crimping machine and the applicator. Be sure to carefully read the operating instructions manual before implementing the work.

■ Applicable electric wires

Check that the electric wire to be used is in the range of application.

If you intend to use an electric wire other than the recommended one, ask our sales personnel.

[Precautions]

- Electric wires that are applicable for crimping connectors shall, principally, be the tin-plated stranded soft-copper wire.
- Crimping of electric wires wherein single wires, polyester yarns, etc., exist and crimping of tin-coated wires should be avoided.
- Avoid crimping two electric wires together.
- The setting values of crimp height (Note 1) may vary between tin-plated and gold-plated terminals even if the same electric wires are used.
- The setting values of crimp height (Note 1) may vary depending on the difference in the core wire configuration even if the computed cross-sectional area is the same.

Note 1 : The crimp height is an important item that determines crimping quality. We execute crimping tests for each electric wire to ensure the optimal value for the crimp height with high precision, thereby ensuring optimal setup values.

Application Pattern

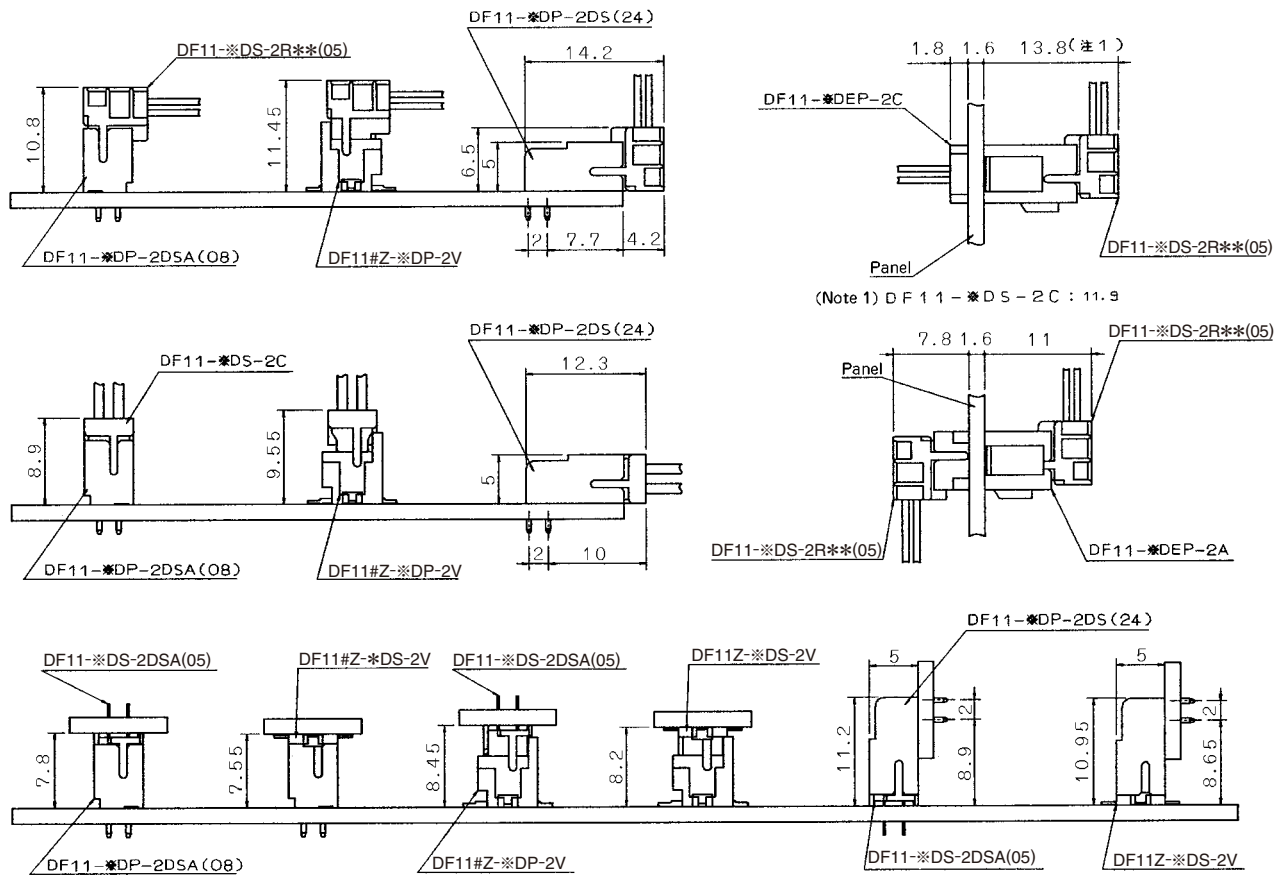

Dec.1.2019 Copyright 2019 HIROSE ELECTRIC CO., LTD. All Rights Reserved.

◆ Embossed Carrier tape Dimensions

● Header (SMT)

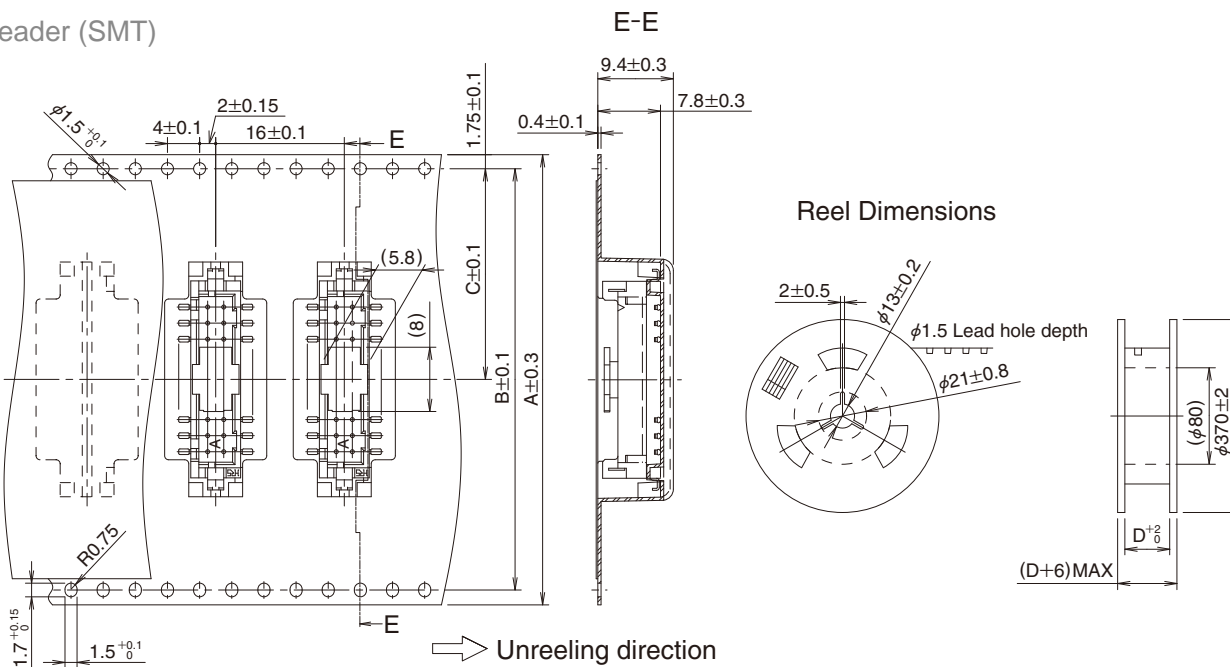

Product Type	Size	No. of Contacts	A	B	C	D
DF11CZ-**-DP-2V(27) DF11C-**-DP-2V(57)		4~8	24.0	—	11.5	24.4
		10~12	32.0	28.4	14.2	32.4
		14~22	44.0	40.4	20.2	44.4
		24~32	56.0	52.4	26.2	56.4
		40	72.0	68.4	34.2	72.4

Unit : mm

● Receptacle (SMT)

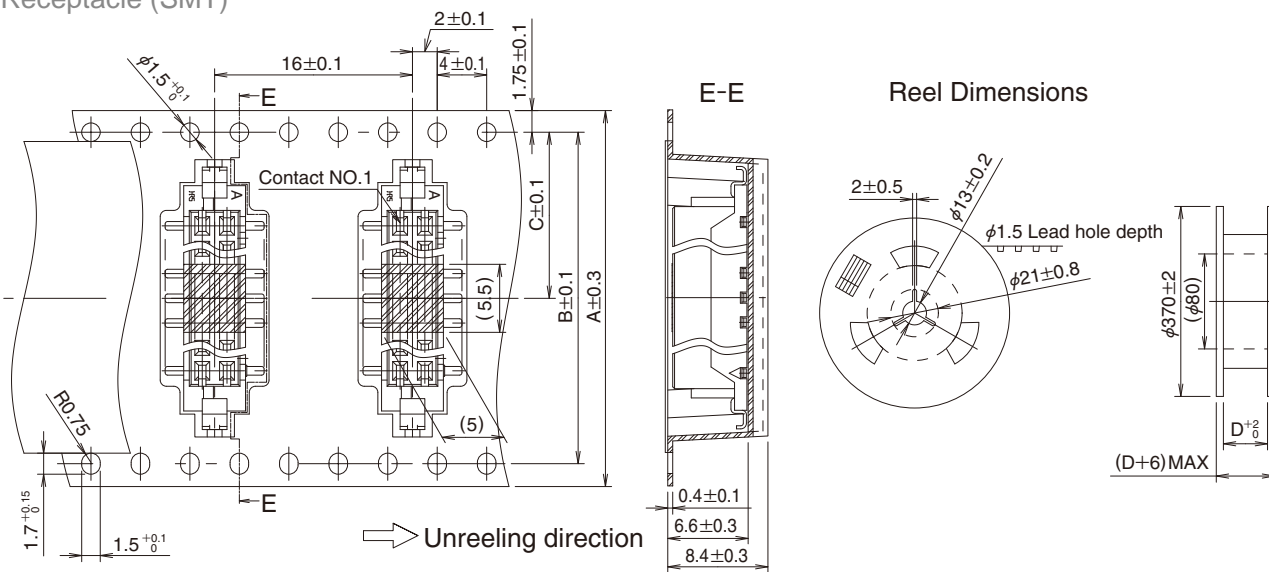

Product Type	Size	No. of Contacts	A	B	C	D
DF11CZ-**-DS-2V		4~8	24.0	—	11.5	24.4
		10~12	32.0	28.4	14.2	32.4
		14~18	44.0	40.4	20.2	44.4
		20	56.0	52.4	26.2	56.4
		22	44.0	40.4	20.2	44.4
		24~32	56.0	52.4	26.2	56.4
		40	72.0	68.4	34.2	72.4

Unit : mm

Dec.1.2019 Copyright 2019 HIROSE ELECTRIC CO., LTD. All Rights Reserved.

◆ Precautions

1. Recommended Temperature Profile (SMT)

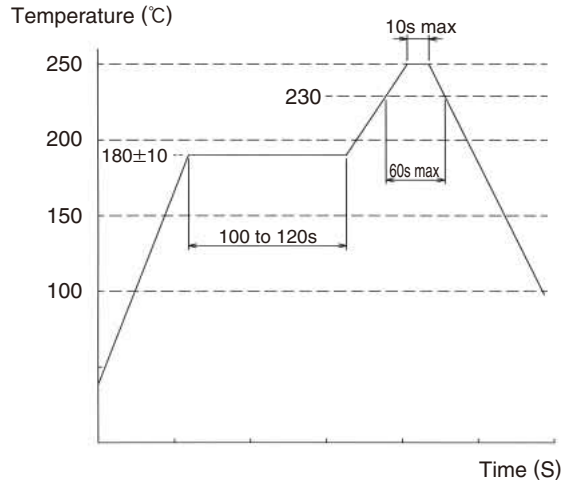

Note 1 : UP to 2 cycles of Reflow soldering are possible under the same conditions, provided that there is a return to normal temperature between the first and second cycle
 Note 2 : The temperature profile indicates the board surface temperature at the point of contacts with the connector terminals.
 Note 3 : This reflow profile is for the connectors packaged in embossed tape(reel), with desiccant in the package.

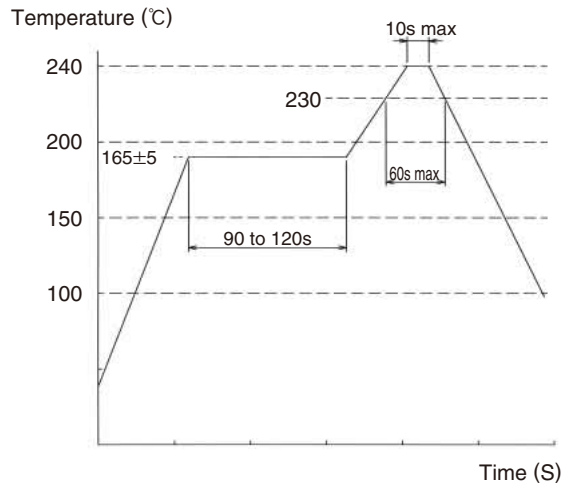

Note 4 : Reflow temperature for SMT connectors in another package is 240°C, 10 sec.max.

2. Recommended Manual Soldering Condition (SMT)	Soldering iron temperature: 290±10°C, Soldering time: Within 2 seconds
3. Recommended Screen Thickness (SMT)	0.15 to 0.2mm
4. Board Warp age (SMT)	Based on the both connector edges, 0.03mm max. is allowed in the connector center area.
5. Recommended Soldering Condition(Through hole)	Flow : 250°C for 10 seconds Manual soldering : 290°C for 2 seconds
6. Cleaning Condition	Refer to the "Wire-to-Board Connector Use Hand book".
7. Connection Condition	Refer to the "Wire-to-Board Connector Use Hand book".
8. Precautions	<ul style="list-style-type: none"> ■ When inserting crimp-type (solderless) terminals to crimping (solderless) sockets, to maintain reliable performance, please do not insert obliquely. ■ Please refer to the documents "DF11 Series Cable assembly Procedure ETAD-H0965-00", "DF11#-****SC**(%%) Crimp quality standards ETAD-H0773-00", "DF11-EP****PC**(%%) Crimp quality standards ETAD-H0935-00" and "Crimp condition" for the cable assembly procedures. ■ Please refrain from pushing/pulling operation when the PCB is not mounted. It may cause breakage, contact deformation, etc. ■ Please refrain from pushing/pulling operation with wires in your hand. It may cause damage. ■ During hand soldering, do not apply flux which will cause flux oozing on connector. ■ This product may have a little difference in its molded color depending on the production lot, but the difference doesn't have any influence on the performance."
9. Handling instructions	<p>Please refer to the following documents in handling this product.</p> <ul style="list-style-type: none"> ■ Crimp quality standards (ETAD-H0773-00, ETAD-H0935-00) ■ Cable assembly Procedure (ETAD-H0965-00) ■ User guide for Wire-to-Board connector

Dec.1.2019 Copyright 2019 HIROSE ELECTRIC CO., LTD. All Rights Reserved.