

REVISIONS				
P	LTN	DESCRIPTION	DATE	APVD
A		RELEASED PER ECO-20-003383	09MAR2020	BKW DS
A1		REVISED PER ECR-20-100211	08AUG2020	JP VS
B		REVISED PER ECR-20-100662	09DEC2020	PC DS

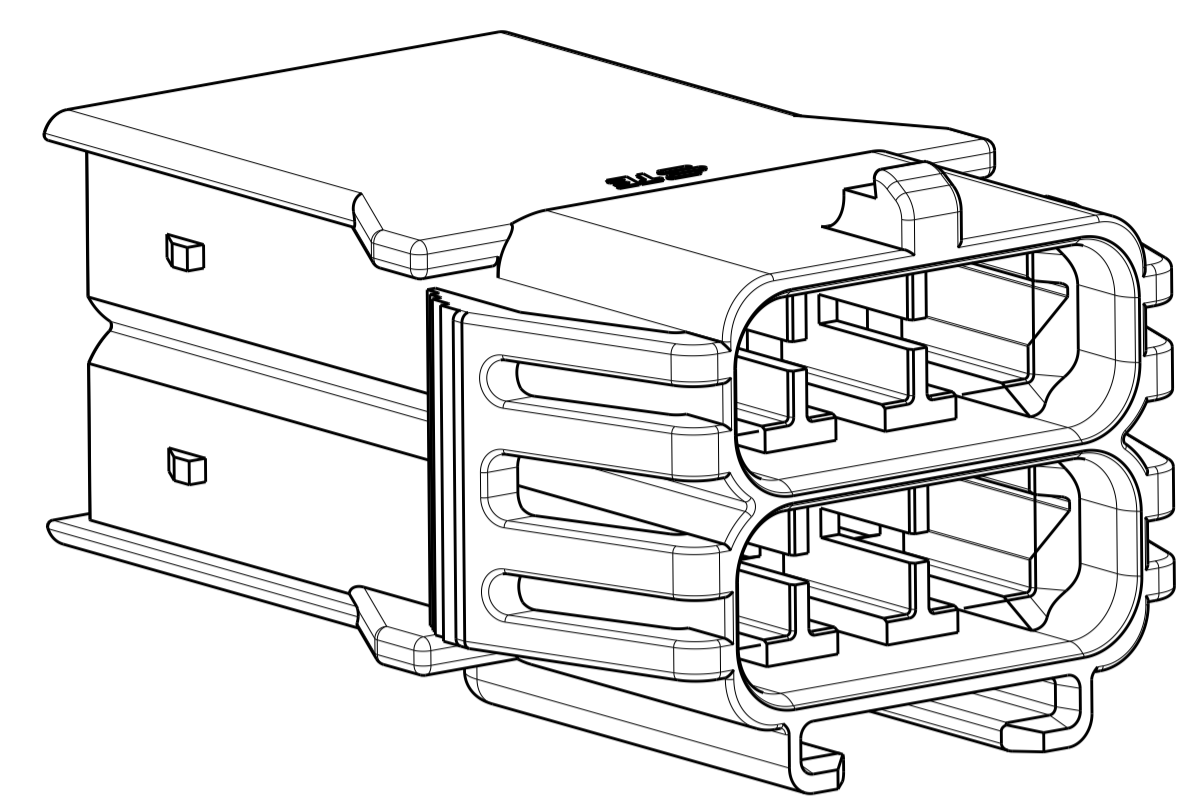

2x3 POSITION

- 1. MATERIAL: PBT, GLASS FILLED
 - 2. FLAMMABILITY RATING: UL94 V-0
 - 3. APPLICABLE CONTACT P/N:
 2329910-*/2329907-*/2329906-*/2329908-*/2329909-*/2329911-*/
 2337140-*/2337139-*
 - 4. MATING CONNECTOR P/N
 PLUG HSG: *-2336229-*/*-2337912-*/
 TPA: 2337218-6
 PERIMETER SEAL: 2325347-3 (2 PER CAP)
 GANG SEAL: 2325349-3 (2 PER CAP)
 - 5. RECOMMENDED PANEL THICKNESS: 0.80-2.00
 - 6. PANEL MUST BE PUNCHED SO THAT THE HOUSING ENTERS THE PANEL IN THE SAME DIRECTION AS THE PUNCH
- ⚠ PRELIMINARY PART - NOT RELEASED FOR PRODUCTION

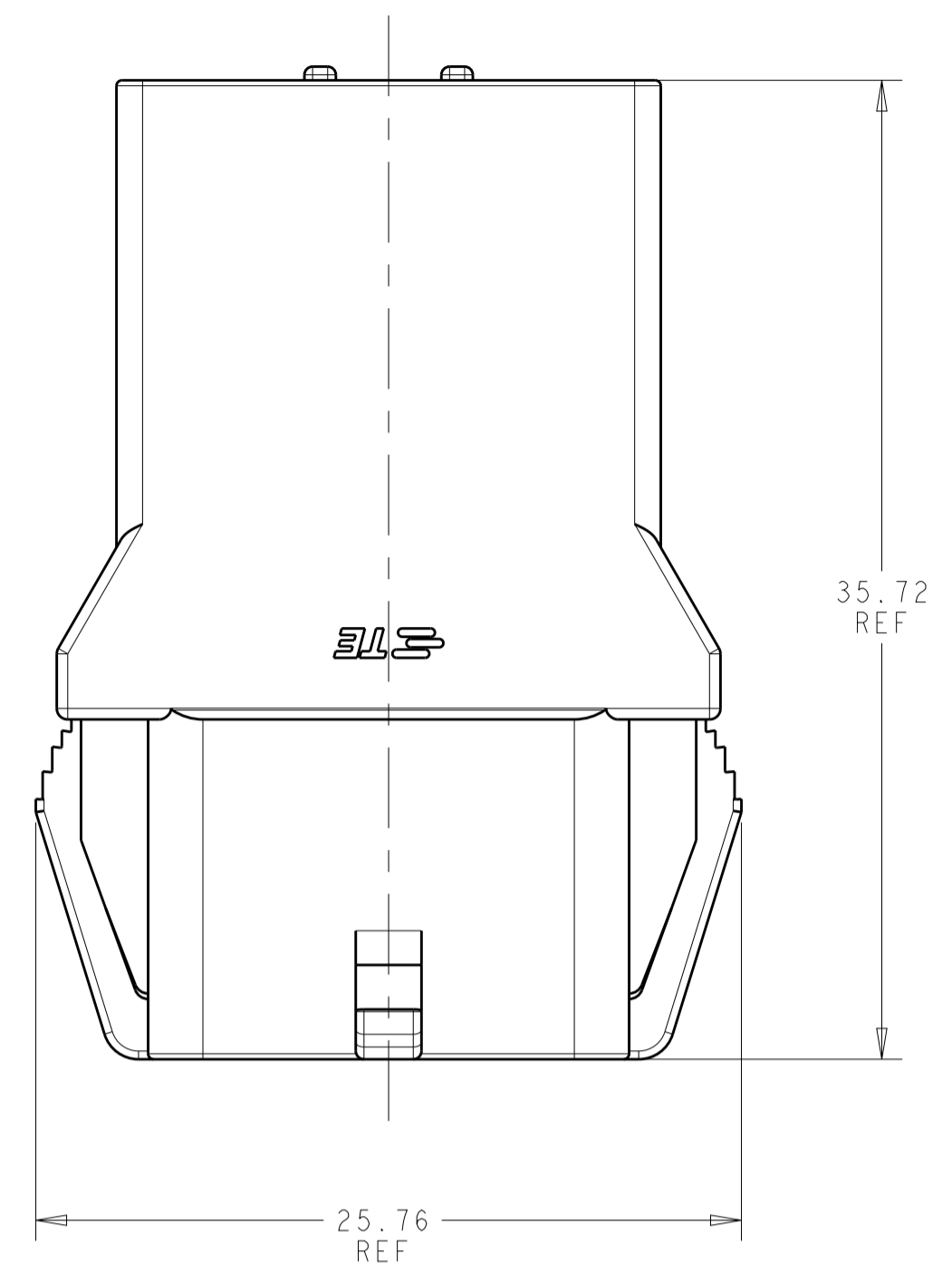
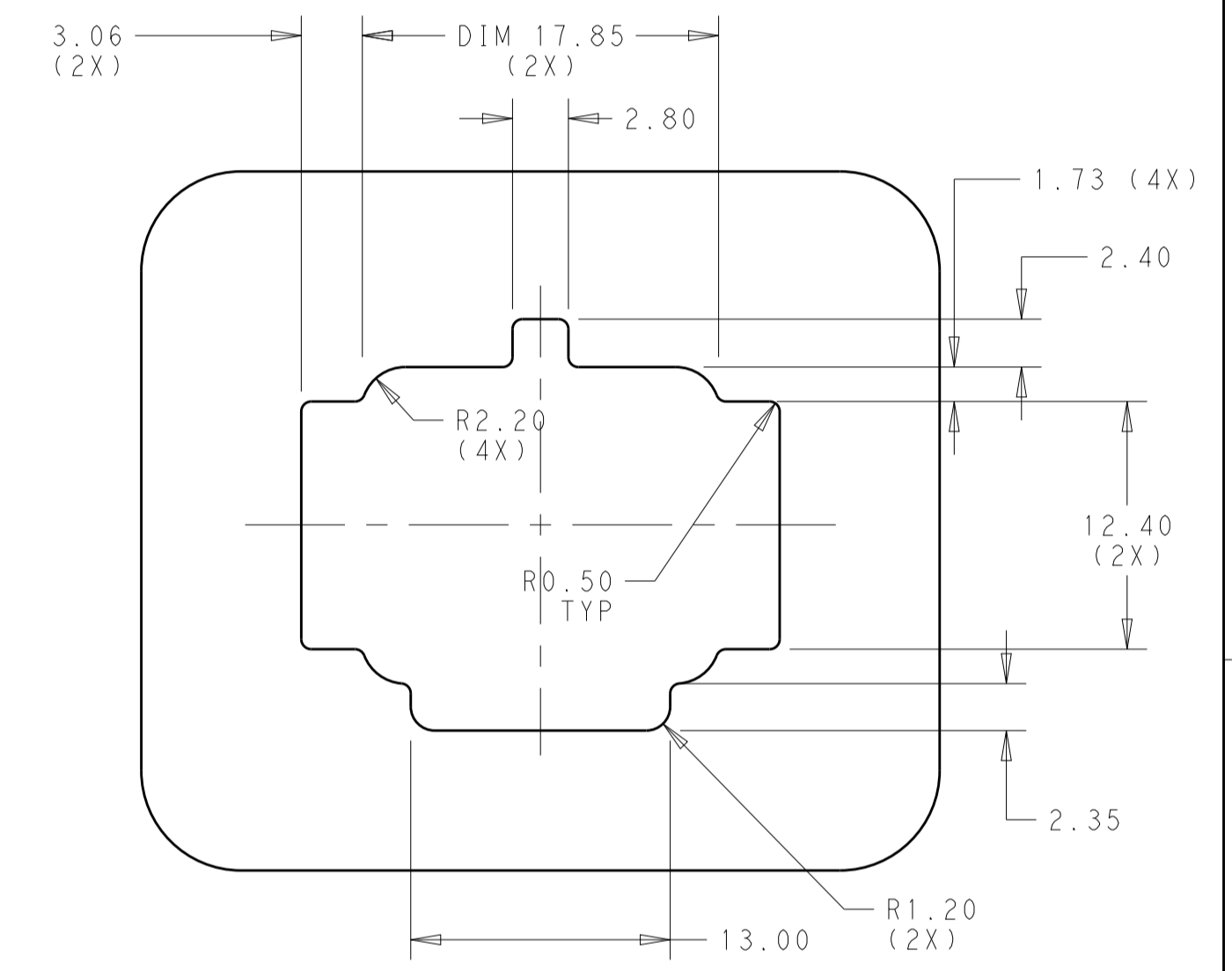
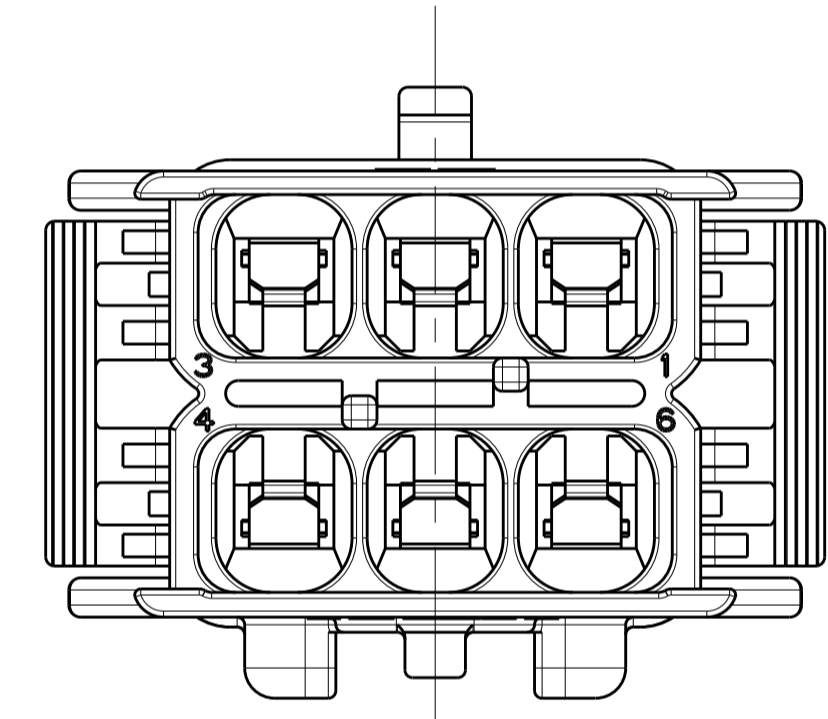
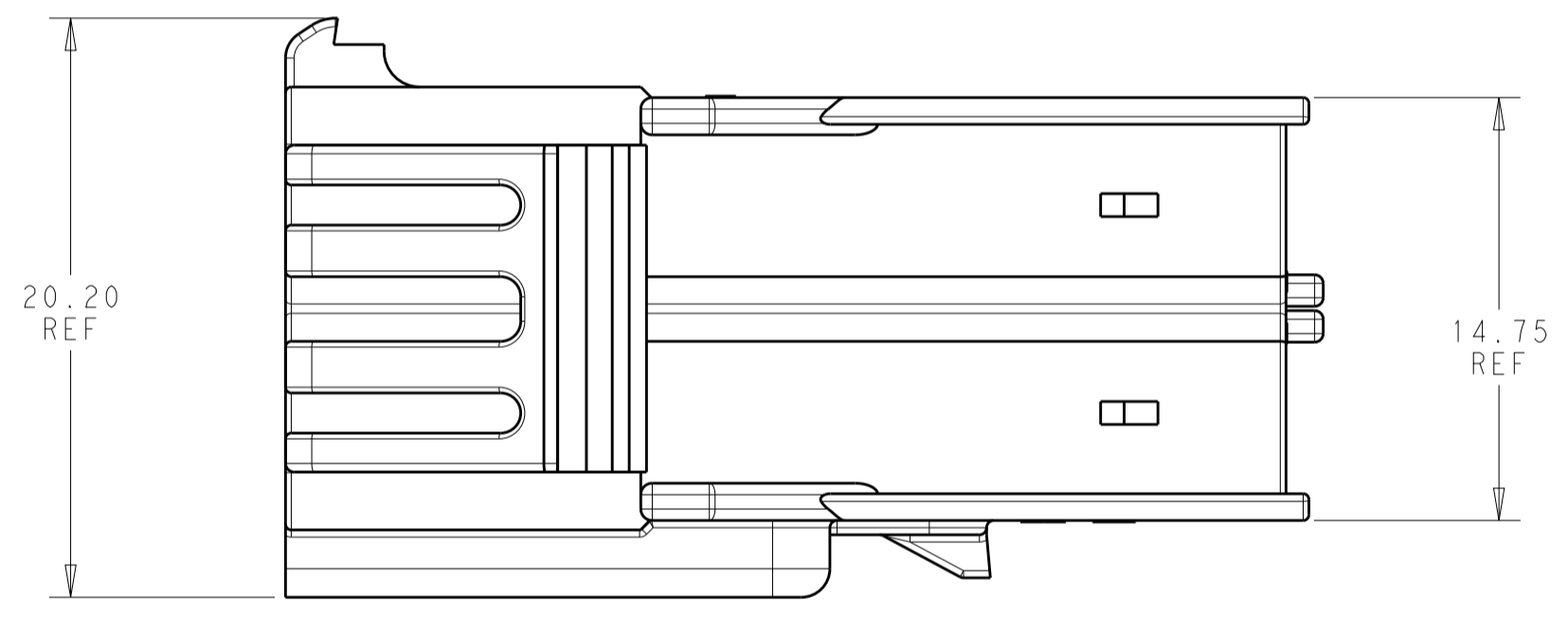
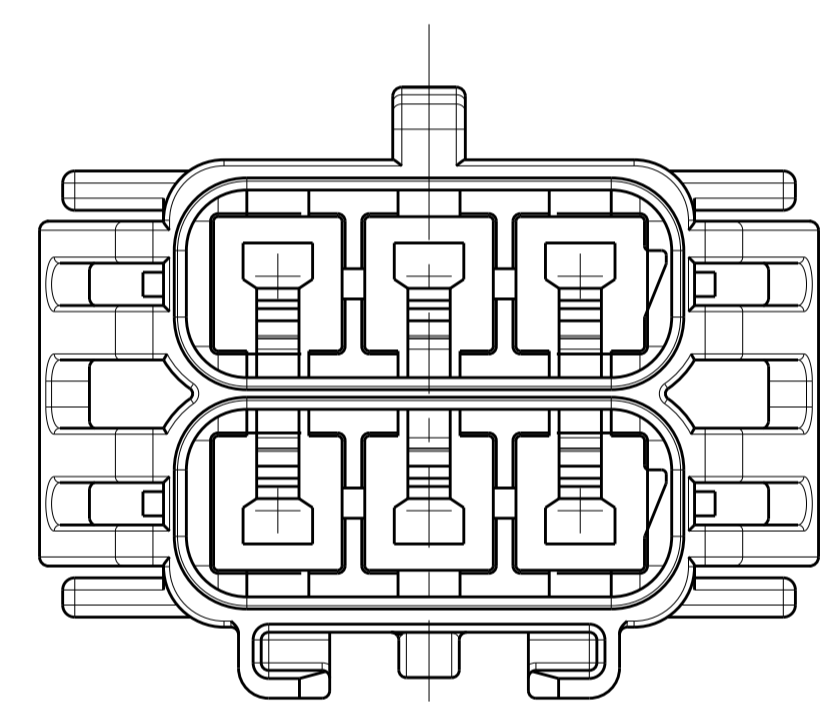

RECOMMENDED PANEL CUT-OUT
 (ALL DIMENSIONS ±0.15)

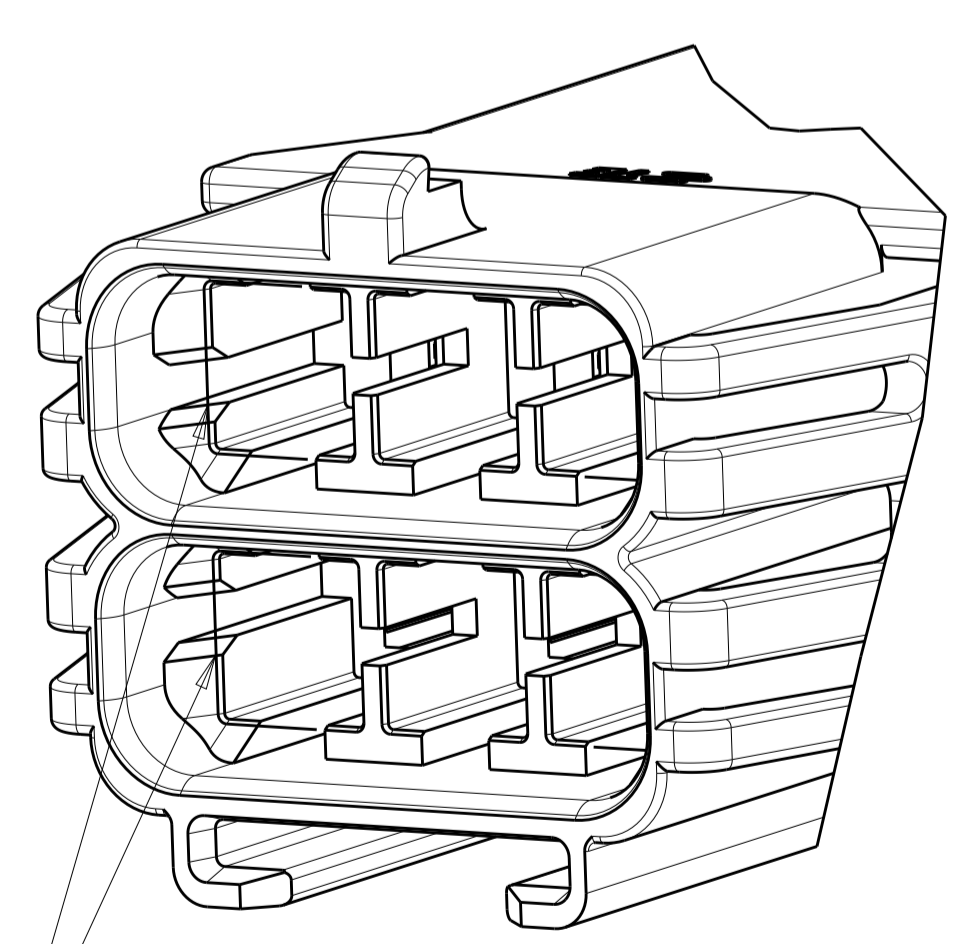
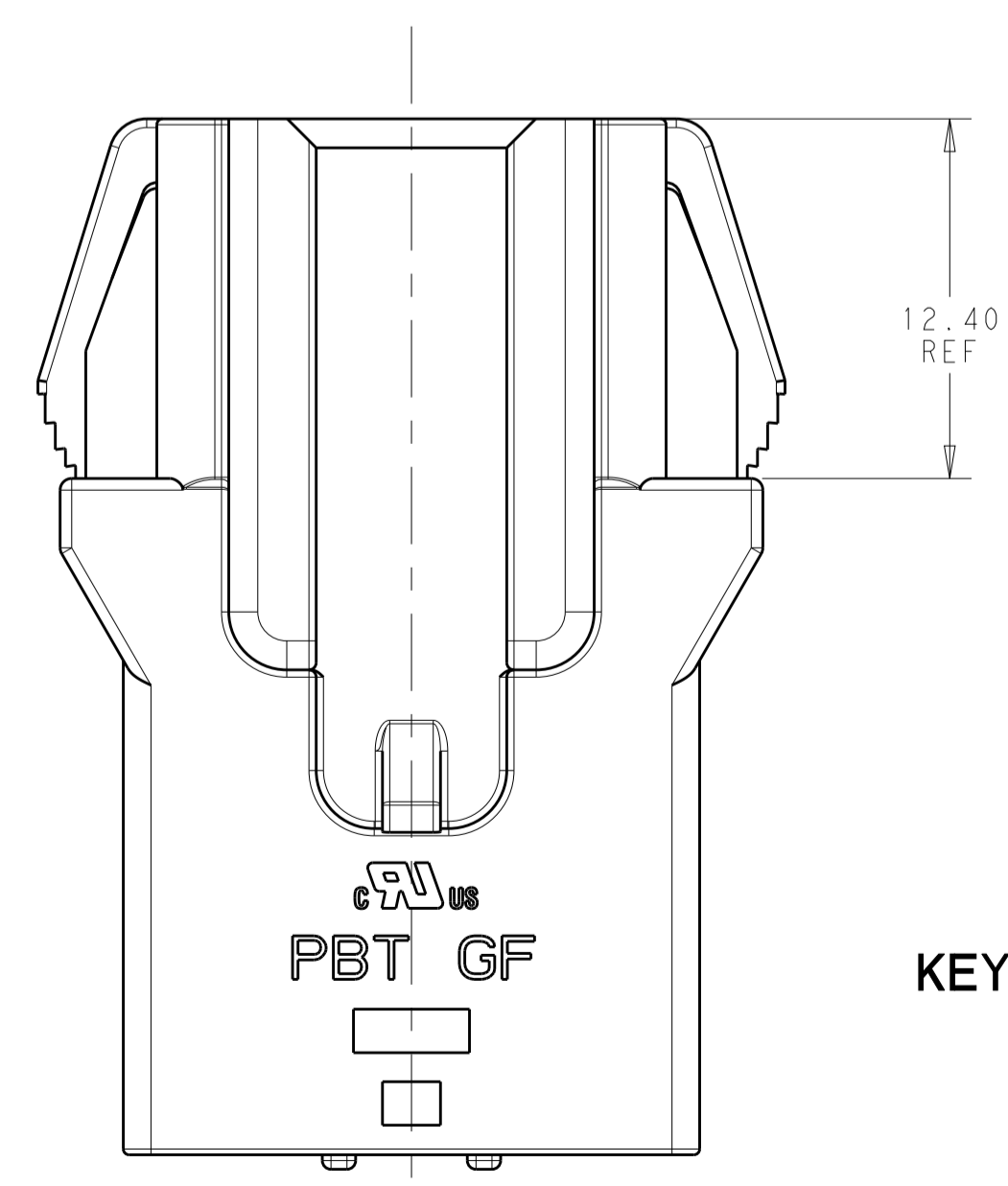

KEY A

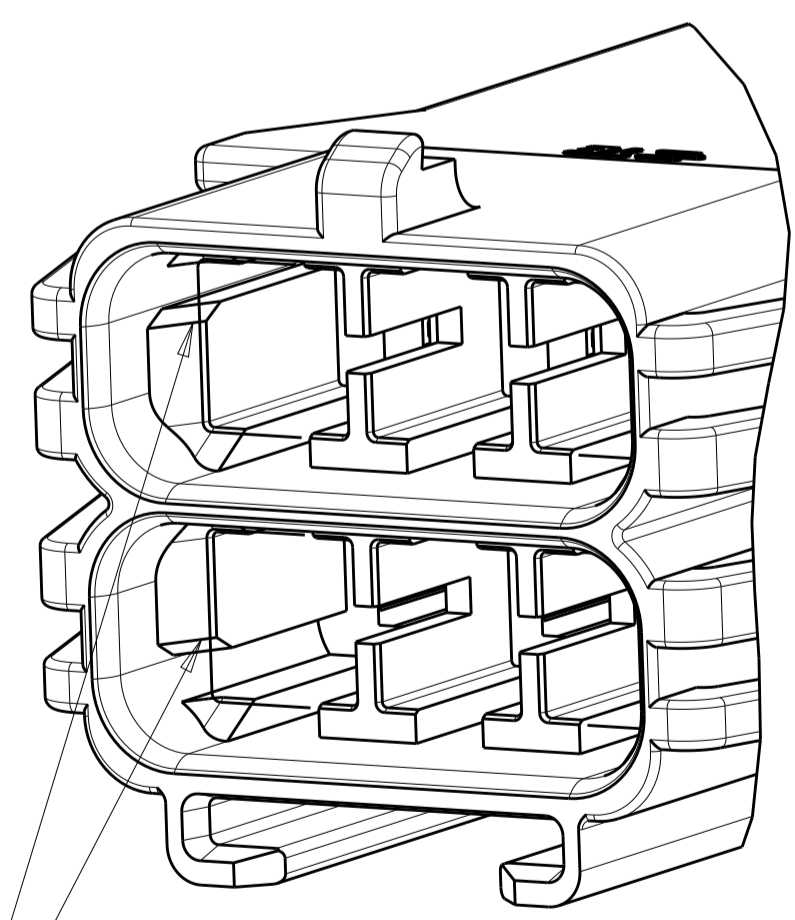

KEY B

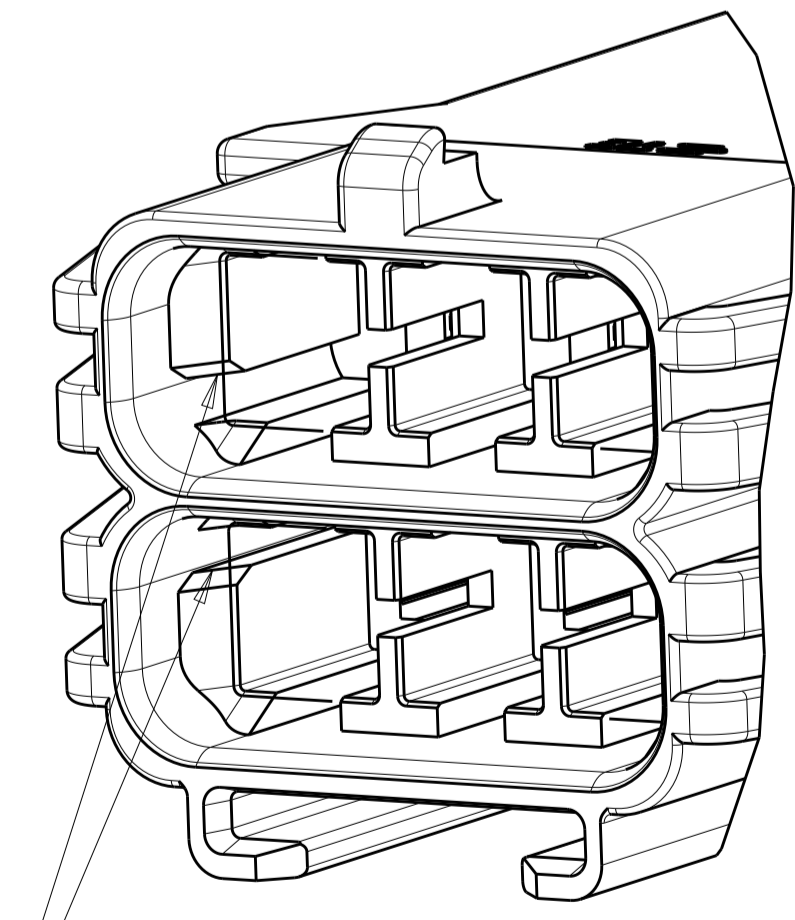

KEY C

COLOR	KEYING	POSITIONS	PART NUMBER
BROWN	KEY C	2*3	3-2337219-6
LIGHT GRAY	KEY B	2*3	2-2337219-6
NATURAL	KEY A	2*3	1-2337219-6

THIS DRAWING IS A CONTROLLED DOCUMENT.

DIMENSIONS:	TOLERANCES UNLESS OTHERWISE SPECIFIED:	DWN: B. WEAVER 20JUN2018	CHK: S. FERNANDES 20JUN2018	APVD: C. YI 20JUN2018
mm	0 PLC ±0.35 1 PLC ±0.25 2 PLC ±0.25 3 PLC ±0.25 4 PLC ±0.25 ANGLES ±0.5	PRODUCT SPEC: 108-143081	APPLICATION SPEC: 114-143082	WEIGHT: -
MATERIAL: PBT GF	FINISH: -	SIZE: A1	CAGE CODE: 00779	DRAWING NO: C=2337219
CUSTOMER DRAWING		SCALE: 4:1	SHEET: 1 OF 1	REV: B

TE Connectivity
 CAP HOUSING, POWER VERSA-LOCK