

SCM1201A Push-Pull Topology PWM Controller

Features

- Built in soft start function,
- Wide input voltage
- Two built-in power MOSFET
- Highly symmetrical drive
- Output short circuit protection
- Over temperature protection

Application

- DC-DC converters

Package

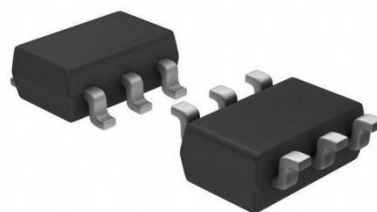

Product package: SOT23-6.
Please see "Ordering Information" for details

Functional description

The SCM1201A is a PWM controller IC for power supplies in push-pull topology. The controller IC even integrates a pair of power MOSFET's. This PWM chip has an ultra-wide input voltage range that allows it to start up and operate normally at a low input voltage of 4V and it tolerates high input voltages is up to 40V without damage. The internal power MOSFET has a high degree of drive symmetry, thus reducing the push-pull topology magnetic bias. To maximize the reliability, the chip design incorporates three key technologies: The first one consists of a soft start function which avoids the impact of booting up under high current conditions that potentially could harm the device, hence ensuring a normal startup in CC mode. The second one being a output short-circuit protection with such a good consistency, which will neither be impaired by a deviation in power supply parameters, nor influenced by high or low operating temperature conditions. Third one is the integrated over temperature protection. If the temperature exceeds the specified range, the controller automatically puts itself into a sleep mode and subsequently self-recovers, once the temperature drops below the set threshold value into a safe operating range.

Typical Circuit diagram

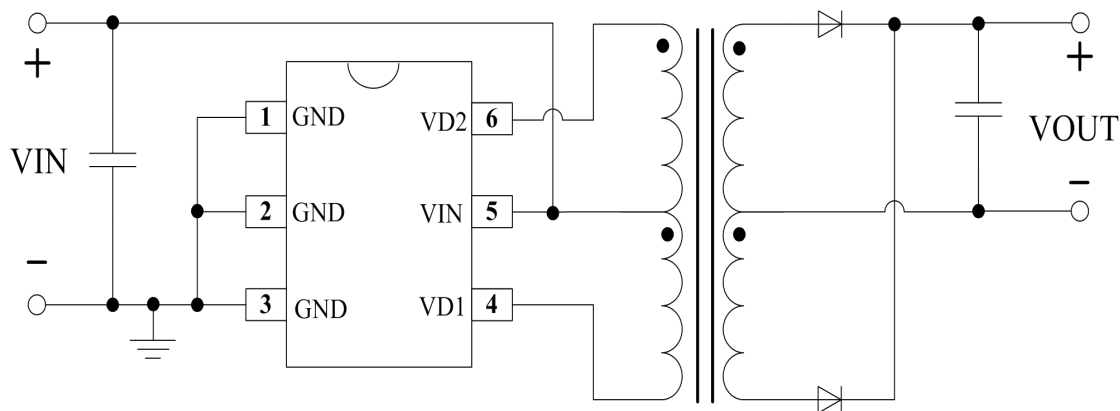

Absolute maximum ratings

Test conditions: Free-air, normal operating temperature range unless otherwise specified, voltage reference is ground.

Parameters		min	max	unit
Continuous input voltage	V_{VIN}	-0.4	40	V
Continuous power MOSFET drain voltage	V_{VD1}/V_{VD2}	-0.7	27	V
Junction temperature range	T_J	-40	150	°C
Storage temperature range	T_{STG}	-55	150	
Lead Temperature, soldering, 10 seconds	0.6mm from case		260	
Moisture Sensitivity Level	MSL	MSL3		
Electrostatic Discharge (ESD)	Human Body Model (HBM)		2000	V
	Charged Device Model (CDM)		1000	

Important: Stress levels exceeding the "Absolute Maximum Ratings" are not recommended, they may severely affect the device reliability and/or result in permanent damage.

Electrical characteristics

General test conditions and $V_{VIN}=5V$, $T_a = 25^\circ C$ (unless otherwise specified).

Symbol	Parameter	Test conditions	Min.	Typ.	Max.	Unit
Supply Section (VIN Pin)						
V_{VIN}	Operating voltage range		4.5		40	V
I_{RUN}	Operating supply current	$V_{VIN}=5V$	0.4	0.8	1.2	mA
I_{START}	Start-up current	$V_{VIN}=3V$		1.26		mA
V_{VIN_ON}	Start-up voltage	V_{VIN} voltage increasing	3.4	3.7	4	V
V_{VIN_OFF}	V_{IN} under voltage lockout voltage	V_{VIN} voltage decreasing	2.7	3	3.3	V
T_{OTP}	Thermal shut-down temperature			162		°C
T_{OTPH}	Thermal hysteresis temperature			32		°C
Drain port of MOSFET (VD1/VD2 pin)						
B_{VDSS}	Breakdown voltage	GATE=0V, $I_{DS}=100\mu A$	27	43		V
R_{DS_ON}	R_{ON} ($V_{VIN}=5V$)	$T_J=25^\circ C$, $I_{DS}=0.2A$		0.38		Ω
		$T_J=100^\circ C$, $I_{DS}=0.2A$		0.47		
R_{DS_ON}	R_{ON} ($V_{VIN}=4V$)	$T_J=25^\circ C$, $I_{DS}=0.2A$		0.43		
		$T_J=100^\circ C$, $I_{DS}=0.2A$		0.53		
I_{SOFT}	Soft start current	$V_{VD1}=V_{VD2}=3V$	350	475	600	mA
Internal time						
F_{OSC}	Operating frequency		246	273	300	kHz
T_{DEAD}	Dead time			170		ns
T_{D_OSP}	Short circuit protection delay time	$F_{OSC}=250kHz$		100		ms
T_{SLEEP}	Short circuit protection sleep time	$F_{OSC}=250kHz$		800		ms

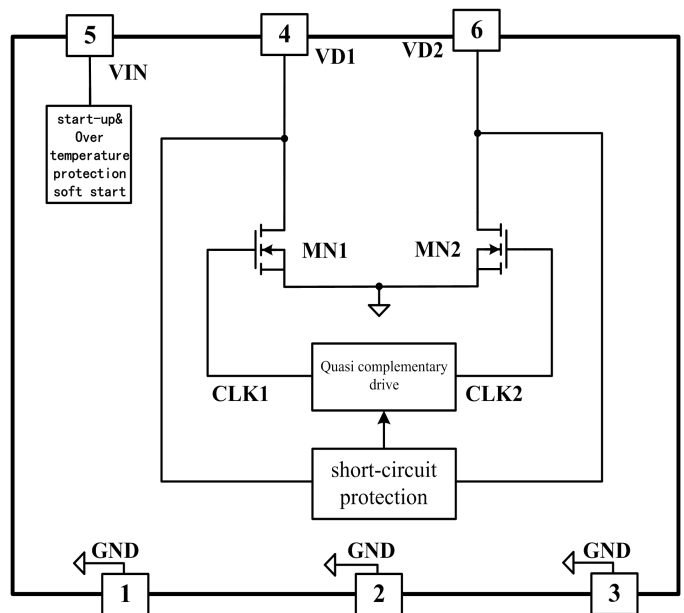
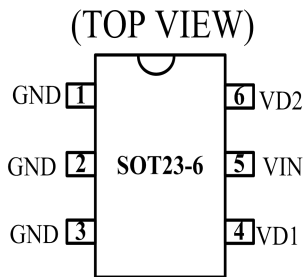

Pin description

Pin No.	Name	I/O	Function
1	GND	I	Pin 1, 2 and 3 are the ground connection of the chip. Pin 2 is the IC's substrate ground potential which is pasted directly through the bottom of the package metal frame to the chip's substrate, therefore ideal for heat dissipation. Pin number 1 and 3 are connected to the built-in power MOSFET's source. For optimized application it is recommended to connect pin 2 and pin 3 to a solid, large heat dissipating ground plane on the mother board for best cooling performance of the device.
2	GND	I	
3	GND	I	
4	VD1	I	Pin 4 and 6 are the built-in power MOSFET's (LDMOS) drain which are driving the transformer windings in a quasi-complementary push-pull way. During startup or when detecting a LDMOS drain voltage larger than V_{TH_OSP} , the chip goes into soft driving stage by limiting the saturation current of the LDMOS. Once the LDMOS turn-on voltage is greater than V_{TH_OSP} , the chip goes into a resting state, with a rest time equal to T_{SLEEP} and the chip restarts after the rest time.
6	VD2	I	
5	VIN	P	Chip power supply port

Ordering information

Part Number	Package type	Number of Pins	Marking Code	Reel information
SCM1201ATA	SOT23-6	6	1201YM	3K/REEL

Product marking

SCM1201xyz:

(1) SCM1201 = Product designation.

(2) x = Version information (Letter from A-Z).

(3) y = Package definition; (T = SOT package).

(4) Z = Operating temperature range (C = 0°C to +70°C, I = -40°C to +85°C, A = -40°C to +125°C, M = -55°C to +125°C).

1201YM

(1)1201 = Product Code.

(2)YM = Date code for product traceability.

Mechanical Package Information

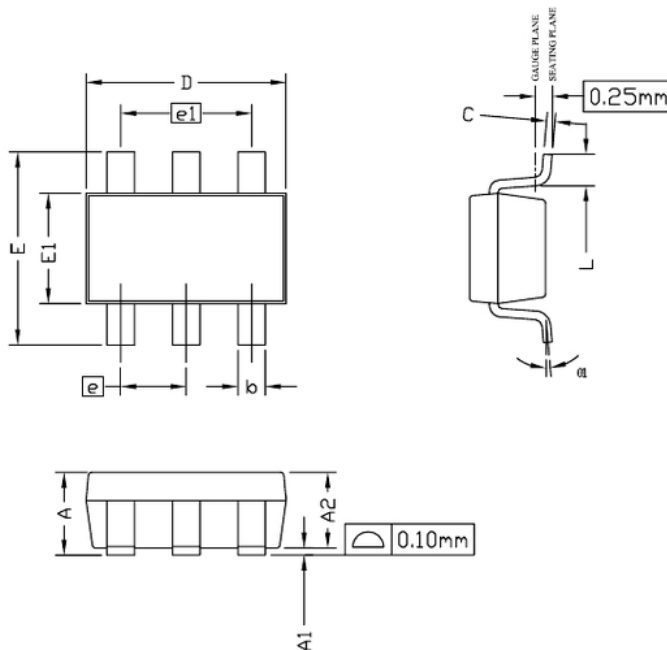

SOT-23-6				
标识	Dimensions in millimeters		Dimensions in inches	
	Min.	Max.	Min.	Max.
A	0.900	1.250	0.035	0.049
A1	0.000	0.150	0.000	0.006
A2	0.700	1.200	0.028	0.047
b	0.300	0.500	0.012	0.020
C	0.080	0.200	0.003	0.008
D	2.700	3.100	0.106	0.122
E	2.500	3.100	0.098	0.122
E1	1.500	1.700	0.059	0.067
e	0.950 (BSC)		0.037 (BSC)	
e1	1.900 (BSC)		0.075 (BSC)	
L	0.300	0.600	0.012	0.024
θ	0°	8°	0°	8°

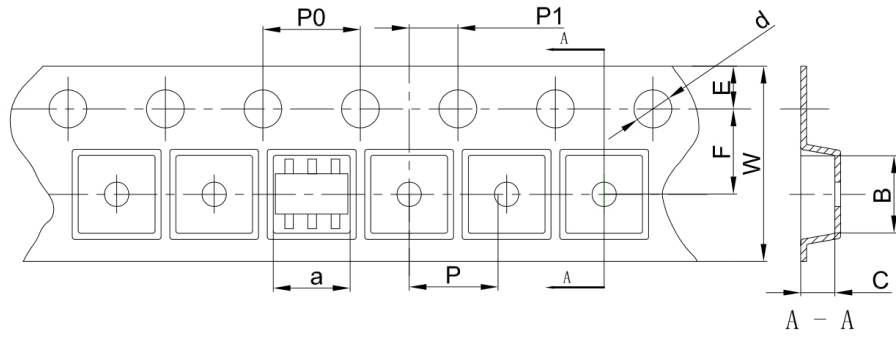

Dimensions in millimeters										
Pkg type	a	B	C	d	E	F	P0	P	P1	W
SOT-23-6	3.17	3.23	1.37	Φ1.55	1.75	3.50	4.00	4.00	2.00	8.00

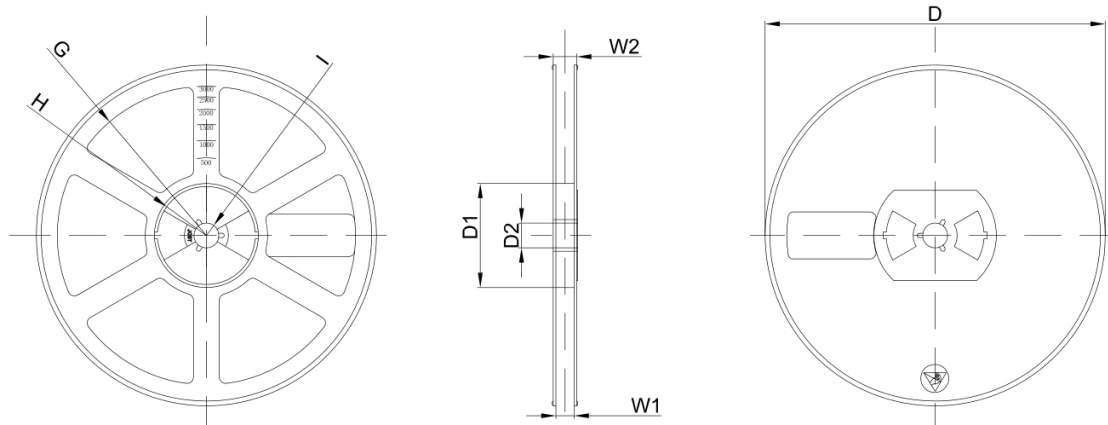
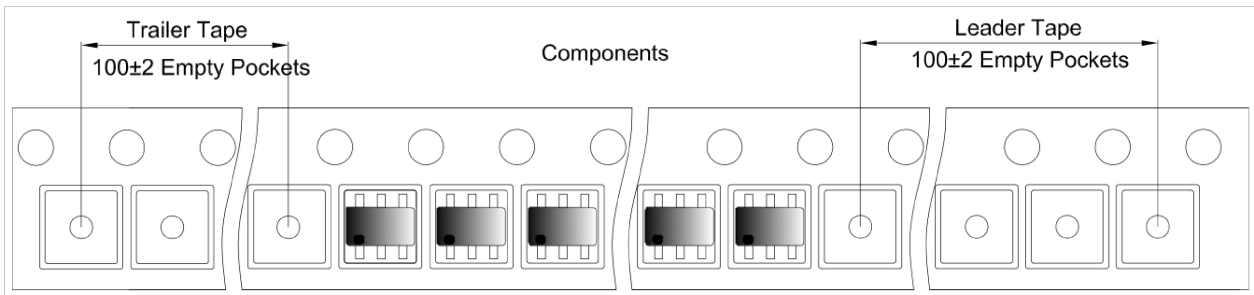

Dimensions in millimeters								
Reel Option	D	D1	D2	G	H	I	W1	W2
7*Dia	Φ180.00	60.00	13.00	R78.00	R25.60	R6.50	9.50	13.10

REEL	Reel Size	Box	Box Size (L x W x H)	Carton	Carton Size (L x W x H)
3000 pcs	177.8 (7 inches)	30,000	203 x 203 x 195	120,000 pcs	438 x 438 x 220

Mornsun Guangzhou Science & Technology Co., Ltd.

Address: No. 5, Kehui St. 1, Kehui Development Center, Science Ave., Guangzhou Science City, Luogang District, Guangzhou, P. R. China

Tel: 86-20-38601850

Fax: 86-20-38601272

E-mail: info@mornsun.cn